

Moist Heat Sterilization

Load types and processes - Autoclave selection
Porous Loads



DARREN BECKETT
TECHNICAL DIRECTOR

Steam Sterilization

General Concepts

What is the killing/sterilizing agents?

- The sterilizing agent is condensing steam, which must be in contact with the micro-organism
- The reference temperature is 121°C (a temperature between 110 °C and 135 °C may be used depending on both the load and micro-organism type)

Why condensing steam?

- When steam condenses, it releases at a constant temperature, a very large amount of heat, this heats the load items rapidly.
- When steam condenses, it's volume reduces significantly, to maintain equilibrium new steam non-condensed steam again reaches the material being sterilized.
- Via steam condensation, load items are rapidly heated to the sterilization temperature.
- Why does steam release so much energy? It's taken this energy from the reverse reaction of evaporation, i.e. when liquid water was converted into steam (latent heat)

Why condensing steam?

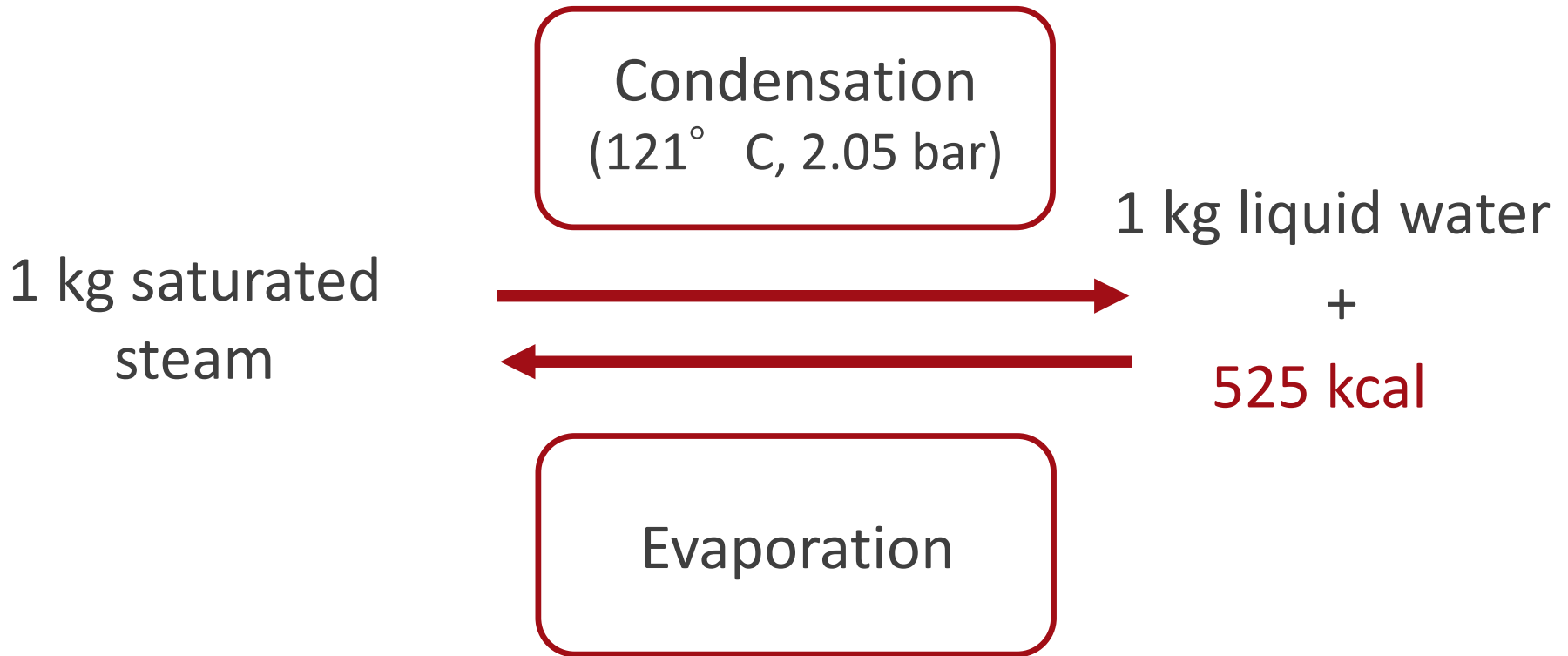

Requirements for a steam sterilization

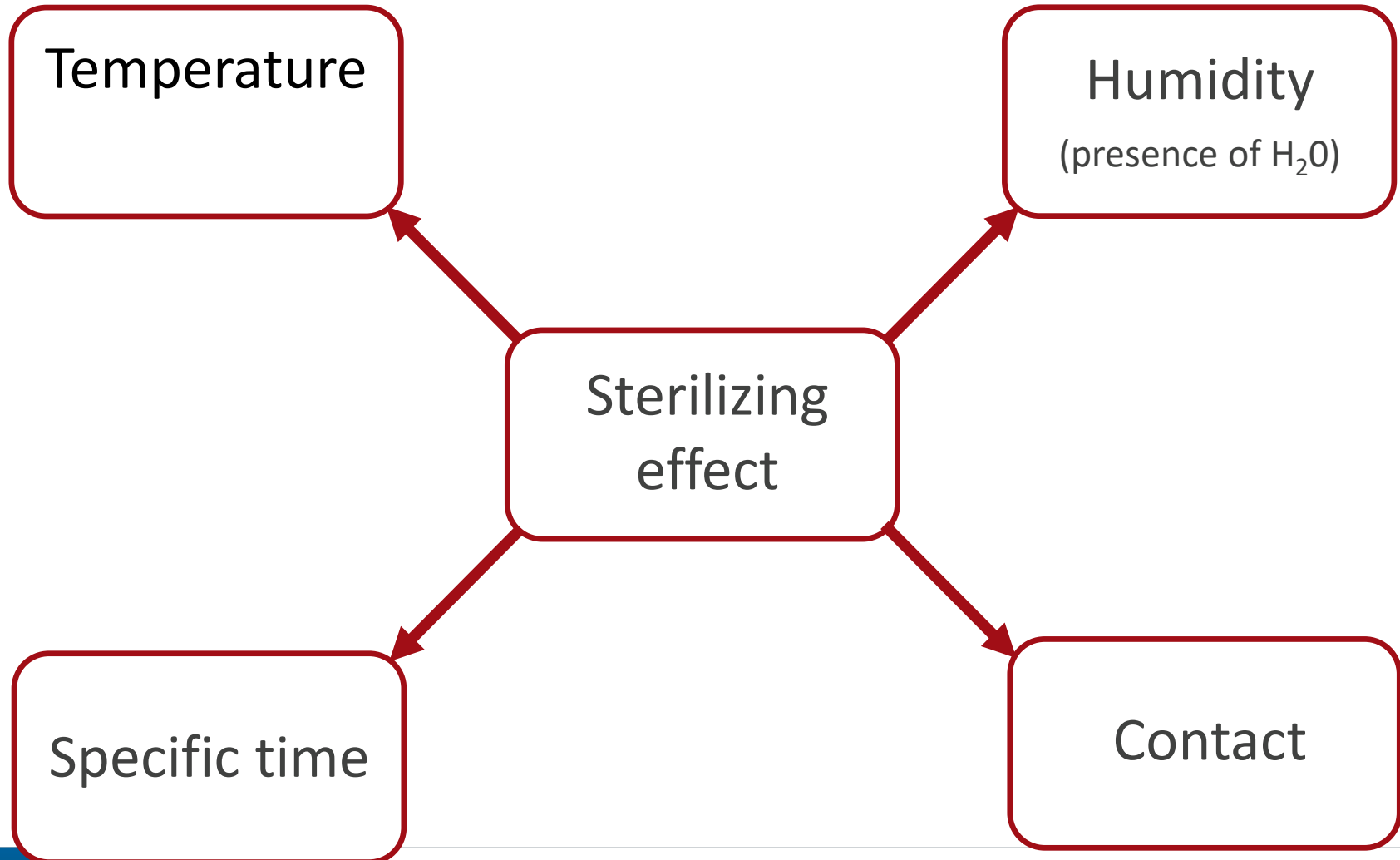

Steam Sterilization



Steam permeable wrapping



Chamber steam heats and sterilizes the load (direct contact)



Chamber steam only heats the load (indirect contact)

The humidity/water necessary to sterilize is present in the product

Steam sterilization for sealed containers

Sterilization is achieved due to the internal steam generated by the aqueous solution inside the container

Consequently...



Can anhydrous oily solution be sterilized by moist heat sterilization?



NO!!!!

Only the outer surface would be sterilized

The temperature and pressure of saturated steam has a one-to-one correlation

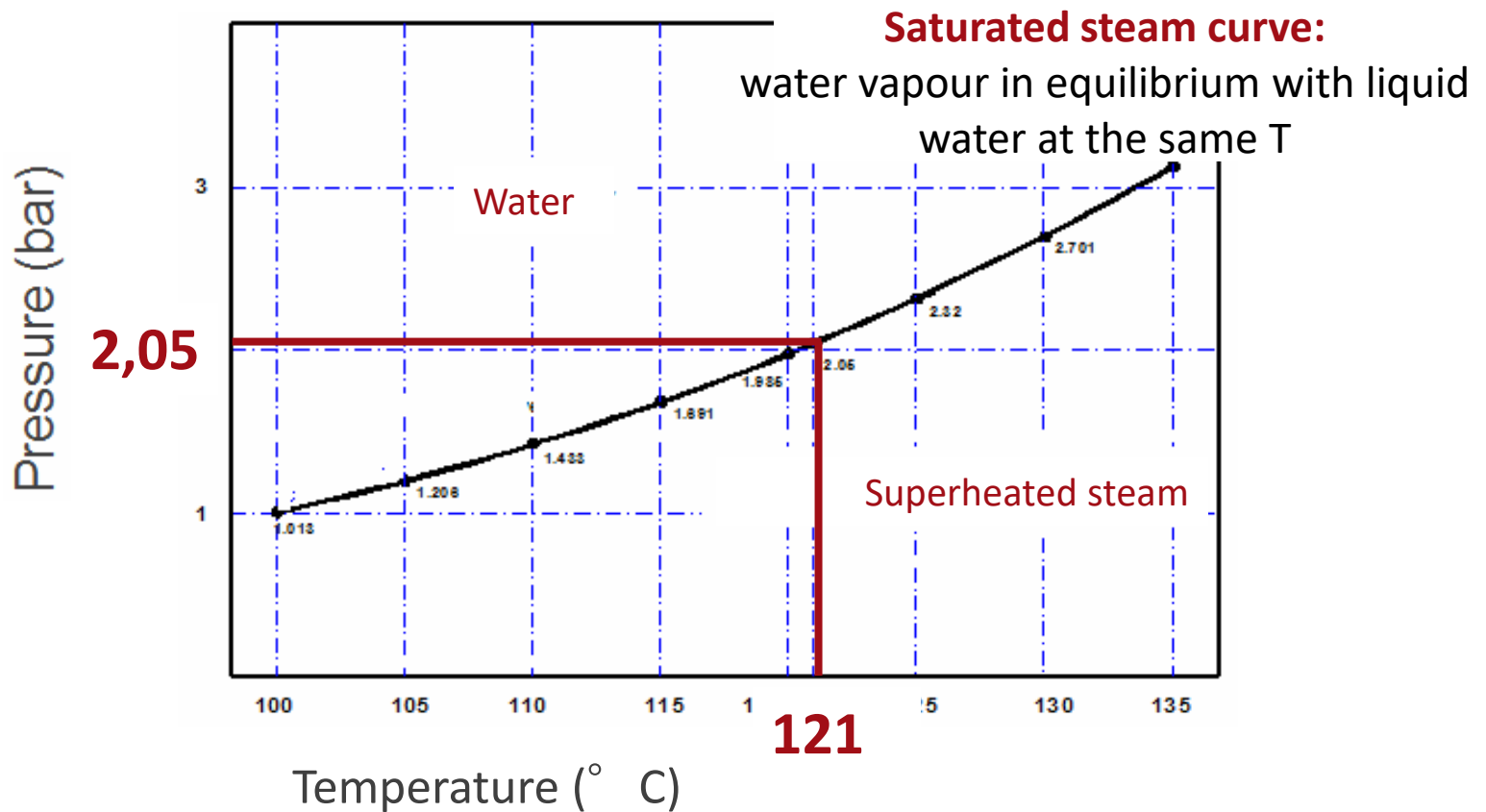

Steam sterilization requirements...

Steam contact



Air must be removed; steam without non-condensable gases

(They stratify at the bottom of the chamber because they are more dense than steam; they limit the heat exchange between steam and product)



Temperature range:
110° C – 135° C
usually 121° C



The pressure inside the chamber is automatically determined (one to one correspondence)

You select the temperature and the control system automatically determines the correct pressure..

Temperature and pressure inside the sterilizer chamber

T (°C)		P (bar)
110		1.5
121		2.05
135		3.1

Moist Heat - Autoclaves

- Saturated steam autoclave
- Superheated water autoclave
- Steam-Air mixture autoclave

Steam Sterilization

Porous/Solid Loads

Glassware

Metallic items

- Surgical instruments
- Machine parts

Porous Loads

- Filters
- Textiles
- Stoppers

Liquid Loads

Sealed containers
(LVP, SVP)

- Standard closed containers (bottles, ampoules, vials)
- Variable volume containers (syringes)

Non-sealed containers

- Flask/plate with culture medium
- Carboy (with filter on vent)

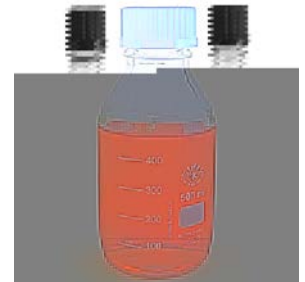

SOLIDS (Hard/Porous loads)

Glassware, plastic tools
(empty)

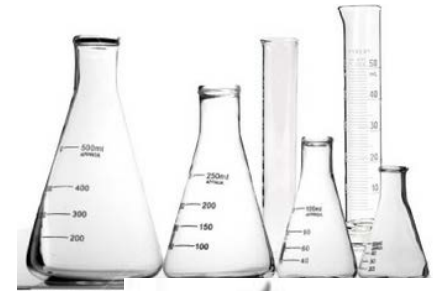

Metallic items
(machine components, surgical instruments, tools)



Filters



Textiles



Stoppers in bag (or not)



Wrapped items
(steam permeable wrapping)



Culture media
(open containers)



Glass ampoules

LIQUIDS



Non deformable
containers and with a
small volume



Glass vials



**They resist
overpressure!**

The difference between the two cycles is the method used to remove air (steam injection or steam-vacuum pulses)

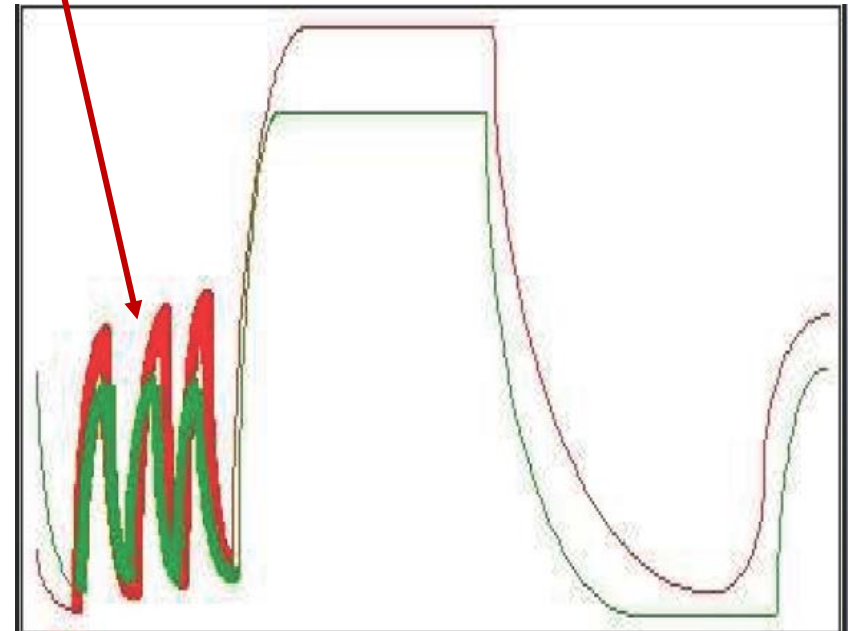
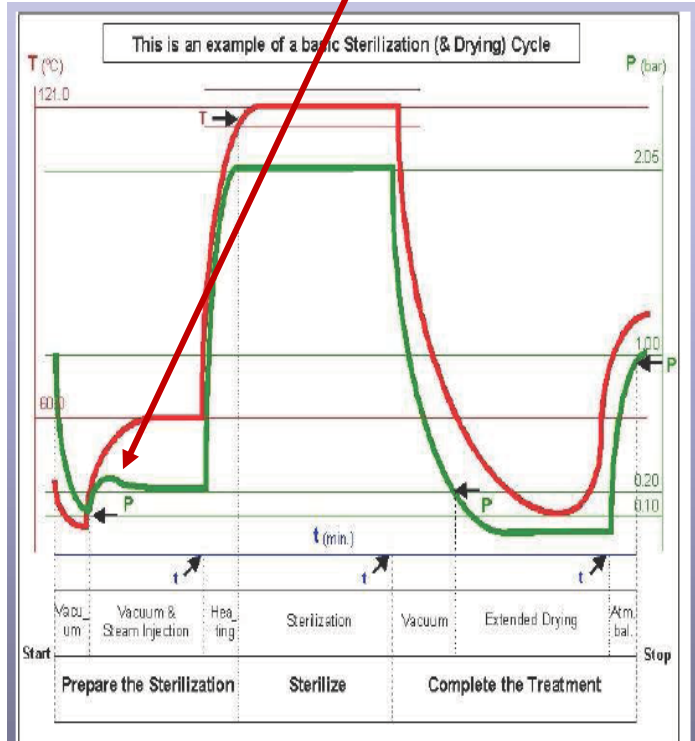

Metal items, empty glassware..

Porous solids (where air removal is critical): filters, textiles, stoppers in bag (or not), hollow materials...

Standard cycle: Process phases (saturated steam)

1. Preheating with hot air (usually for loads very hard to dry) or other auxiliary treatments

Standard cycle: Process phases (saturated steam)

1. Preheating with hot air (usually for loads very hard to dry) or other auxiliary treatments
2. Air removal from the chamber (e.g. By vacuum)

Standard cycle: Air removal

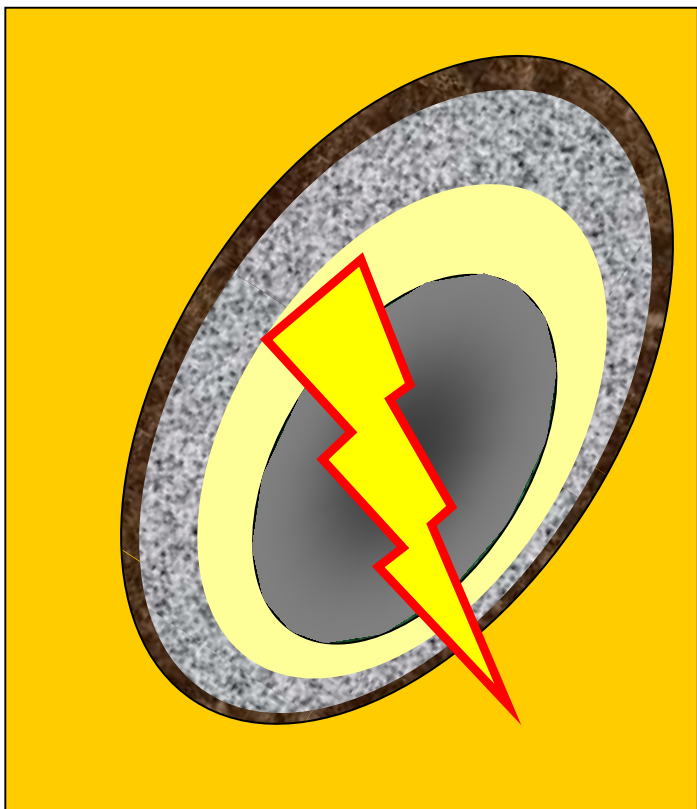

Dry heat relies solely on thermal destruction of the membrane and slowly attacks the cell layer by layer.

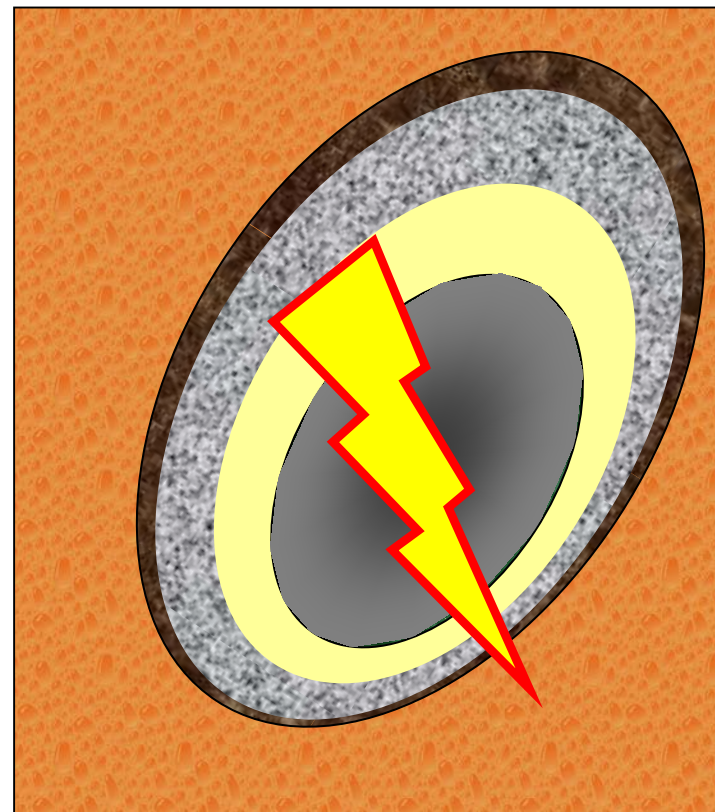

Moist heat also hydrates the outer membrane, helping heat penetration & destroying the cell more rapidly.

To ensure **moist heat** conditions throughout the load
 - i.e. only steam present, we must first remove all the air

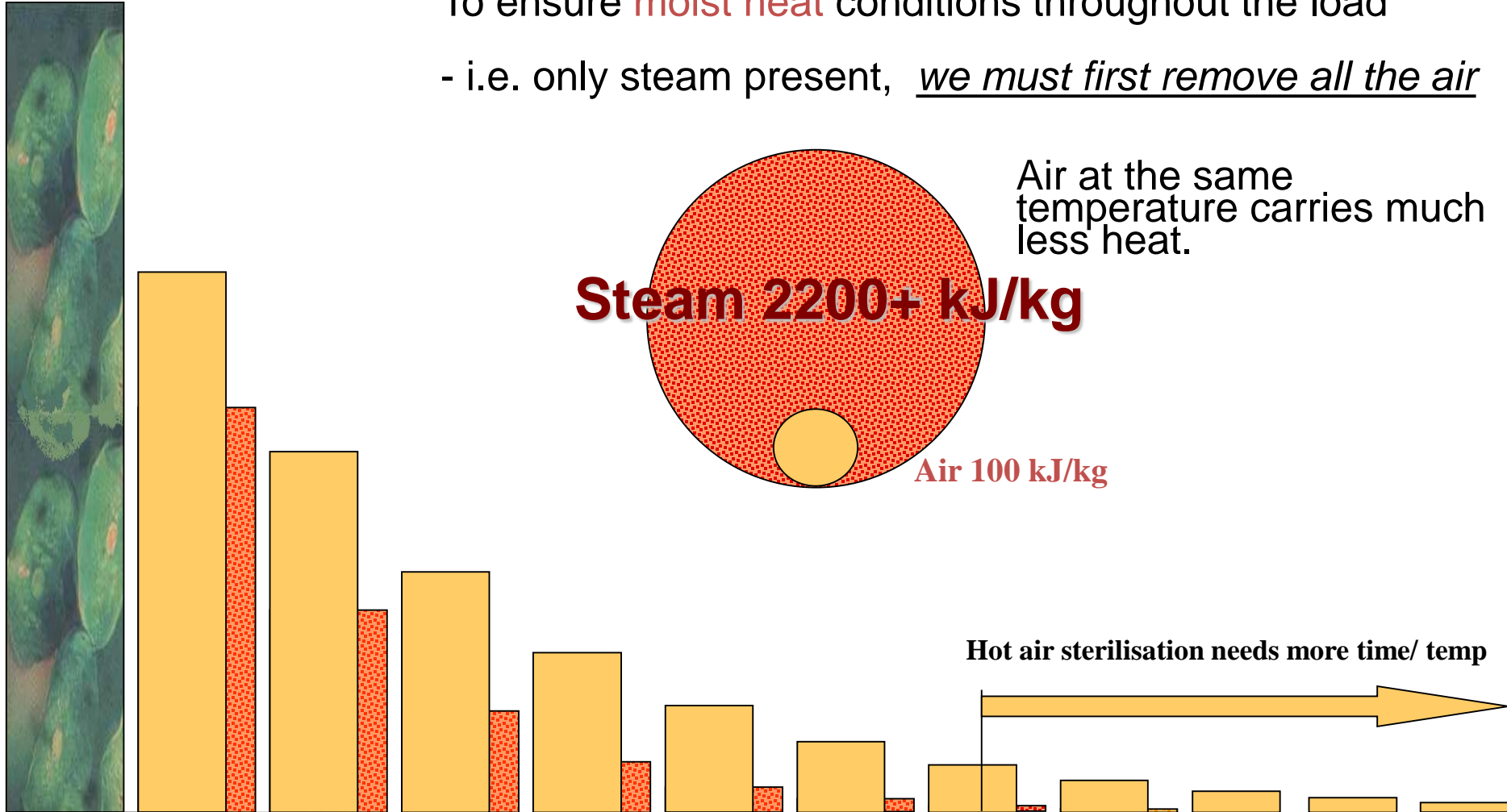

Pressure controls Temperature....
.....as long as it is just dry saturated steam

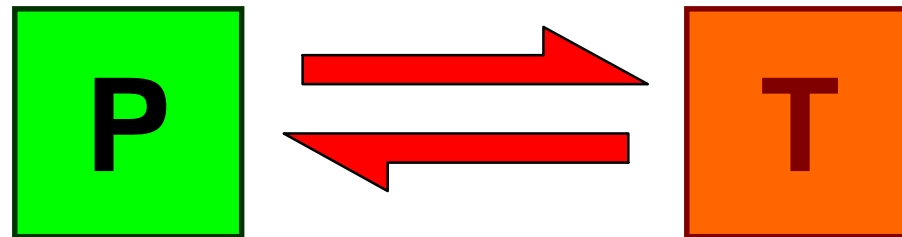

It is much easier to regulate pressure accurately than to try to measure temperature and respond to that.

Steam injection

Once the initial vacuum has been reached, steam is injected for a few minutes while the vacuum pump is kept continuously running.

The injected steam expands and superheats at a low temperature.

It consequently produces calories: heating of the load and consequently generating a small amount of condensate.

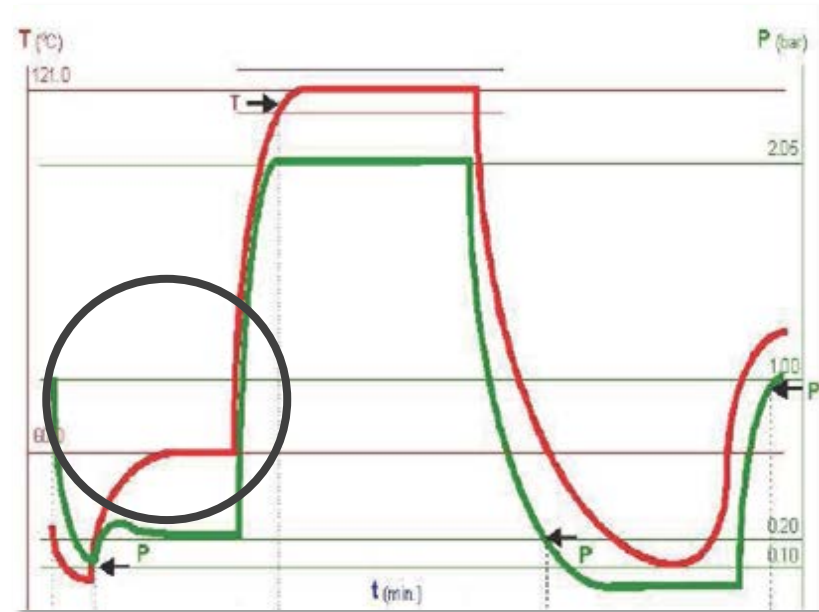

Steam injection

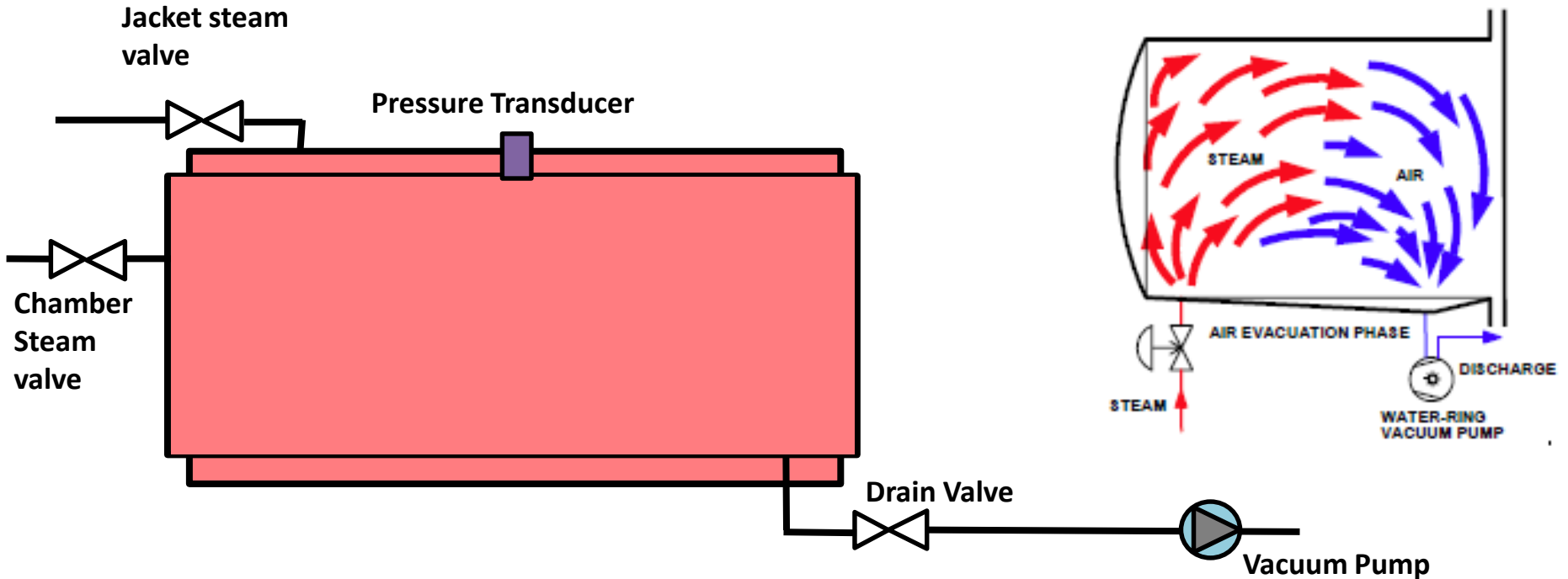

Steam is injected into the chamber displacing the air, the vacuum pump extracts both steam/condensate and air from the chamber.

Steam injection

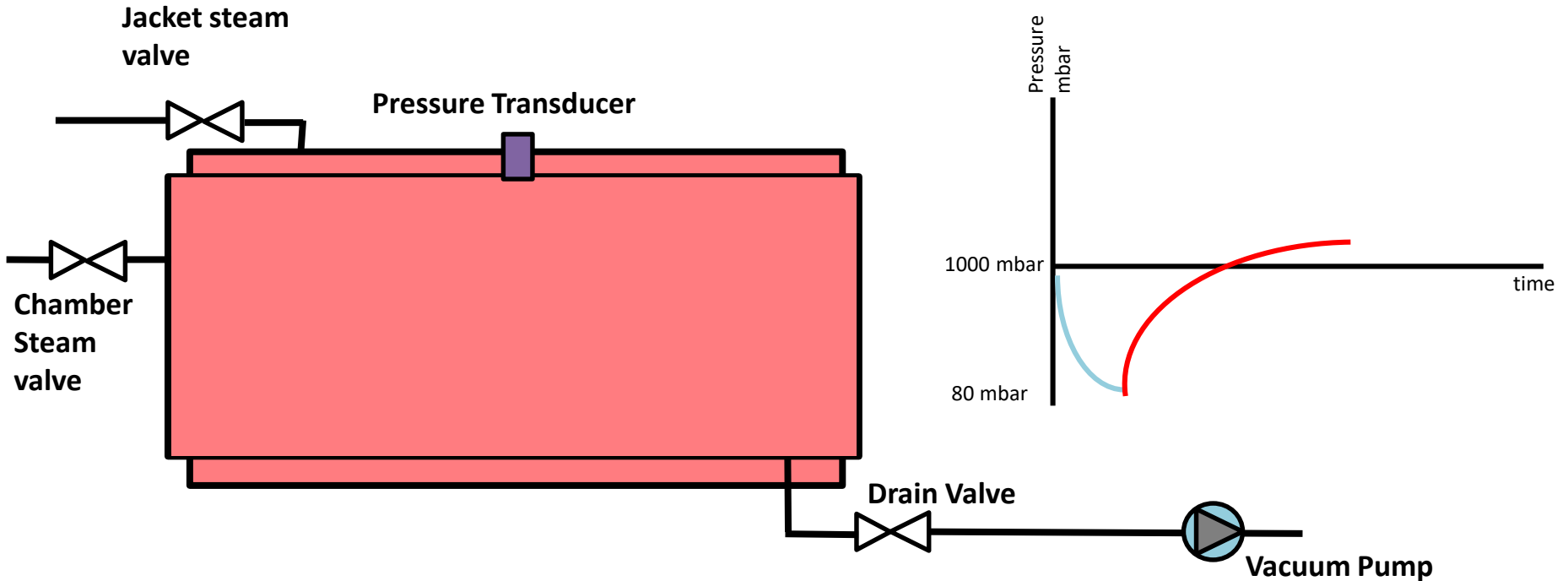

Steam is injected into the chamber displacing the air, the vacuum pump extracts both steam/condensate and air from the chamber.

Steam pulsed air removal

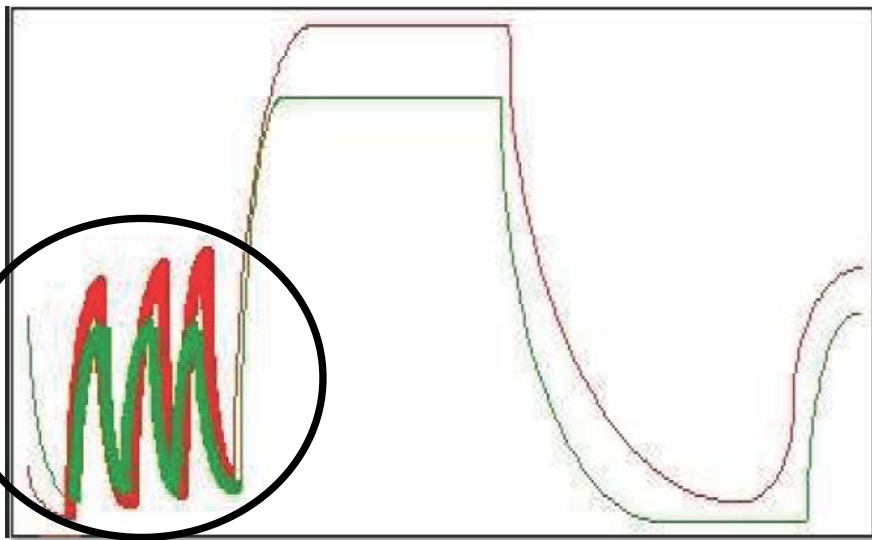

Once the initial vacuum has been reached, the program enters the pulsed air removal stage.

This consists of a number of repeats of a set sequence 'Steam rising Pulse, Falling Pulse', both the rising and falling pressure targets are set within the program, as are the number of pulse repeats

Initial air removal from the chamber – Steam pulse air removal

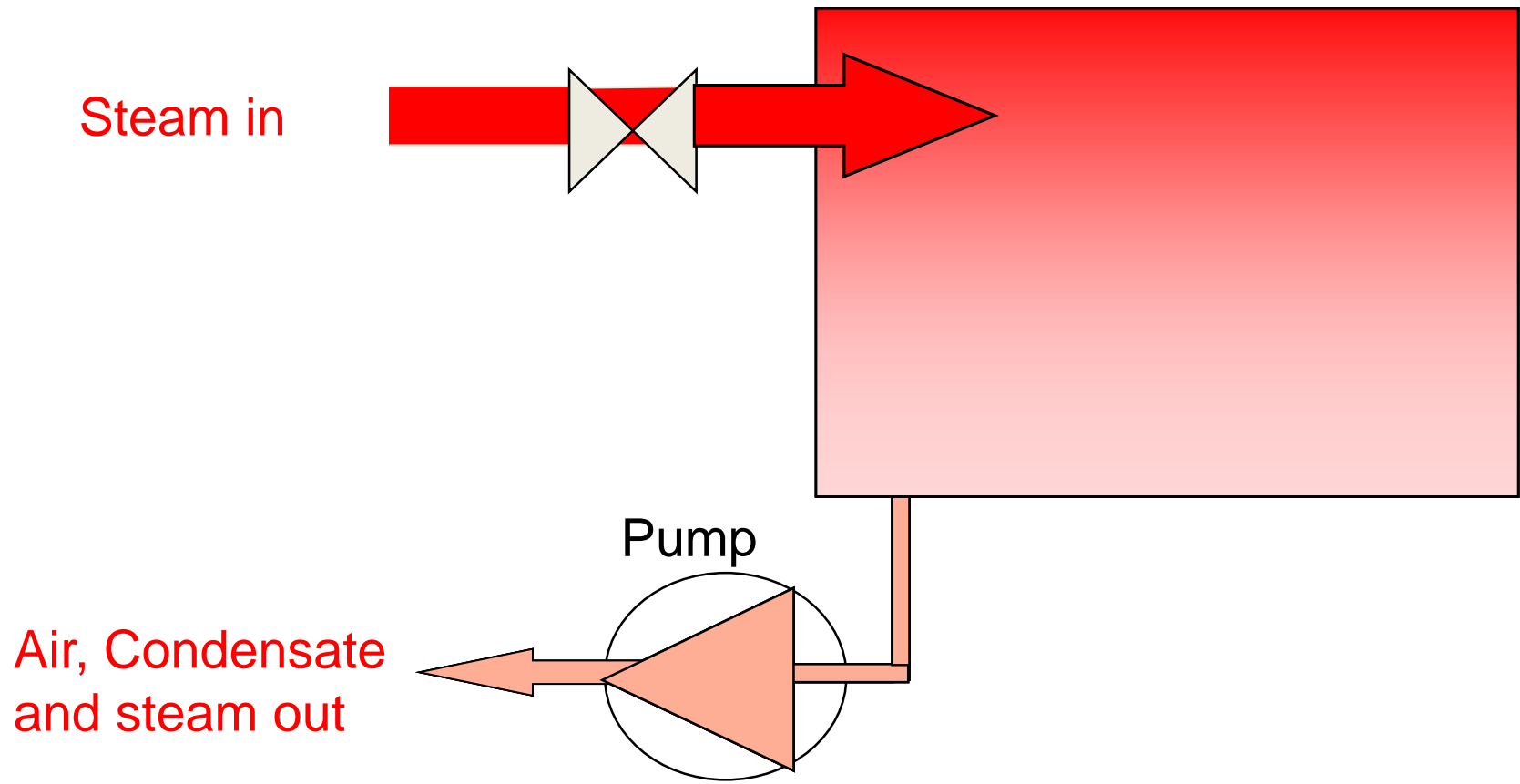

Initial air removal from the chamber – Steam pulse air removal

Initial air removal from the chamber - Pulsed Air Removal

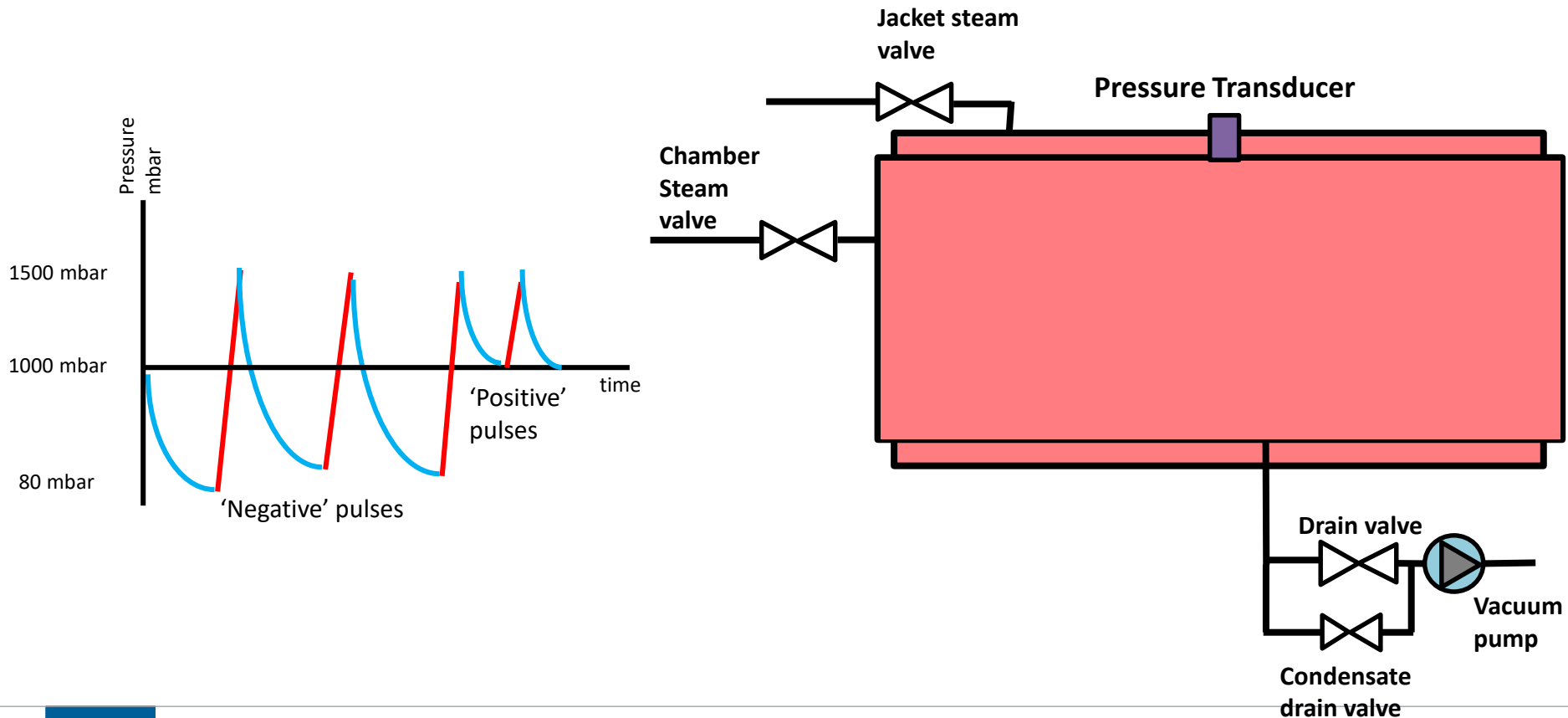

Steam pulse air removal

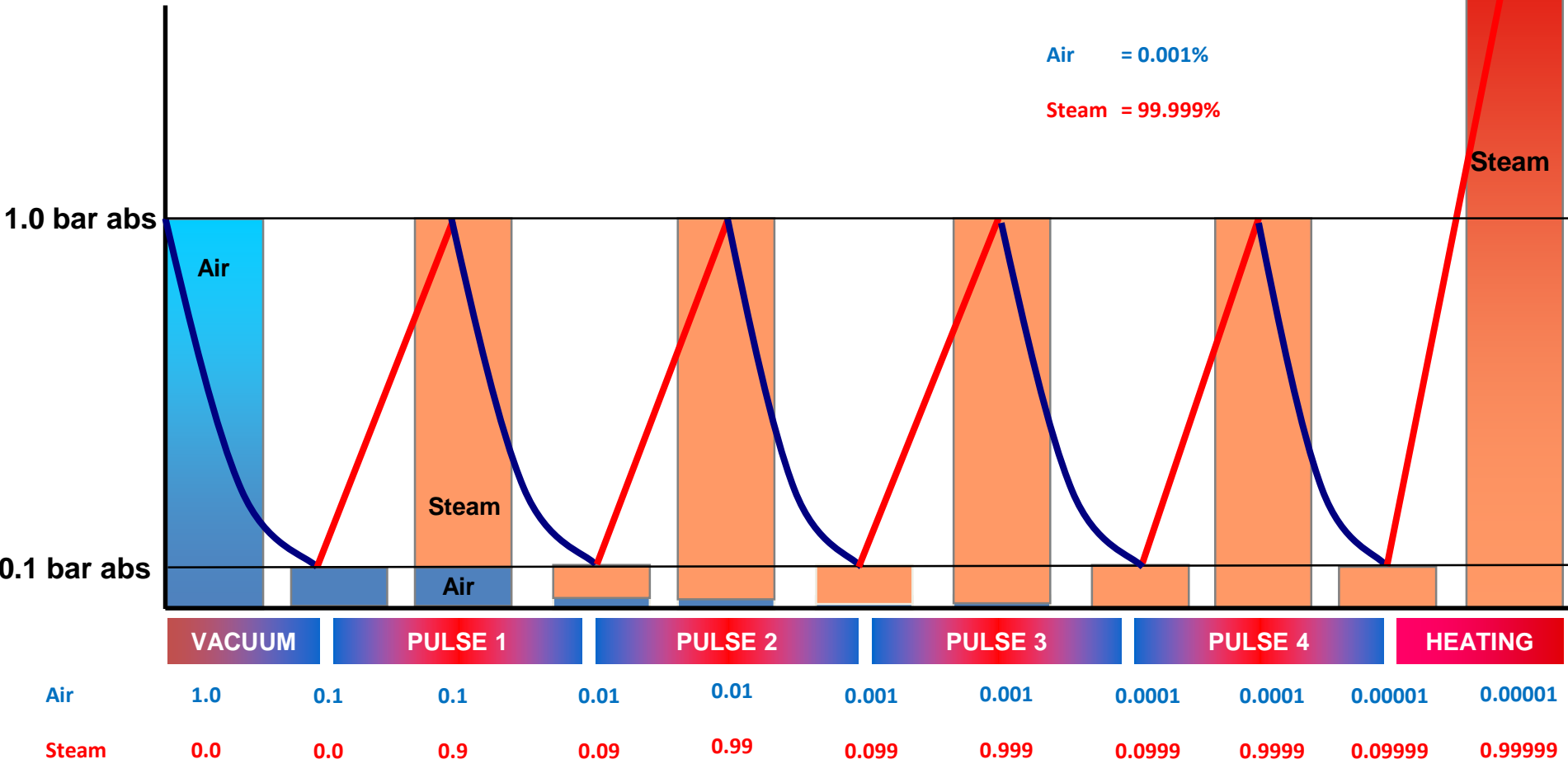

Steam pulsed air removal – for delicate loads

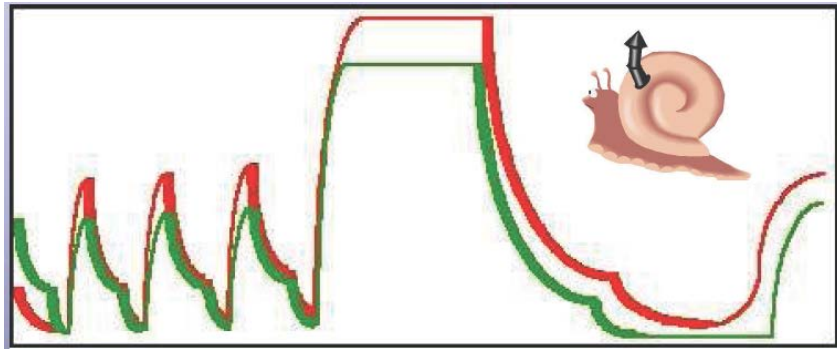

For loads that cannot tolerate rapid pressure changes, such as filters, membranes, stoppers in bags, a modified pulsed air removal process is required.

The use of a modulated pulsed air removal phase can be used to manage this process. This process is intentionally slow and can significantly increase cycle time.

Steam pulsed air removal – What could go wrong?

A leak on the autoclave may let air in during those vacuum pulses.

There may be air (or other “non-condensable gasses” like CO₂) in the steam

Is an Air Detector fitted??

Has the load been correct developed, are we sure we are removing all the air from all the components in the load?

Steam pulsed air removal – Air Detection

Has the air really gone??

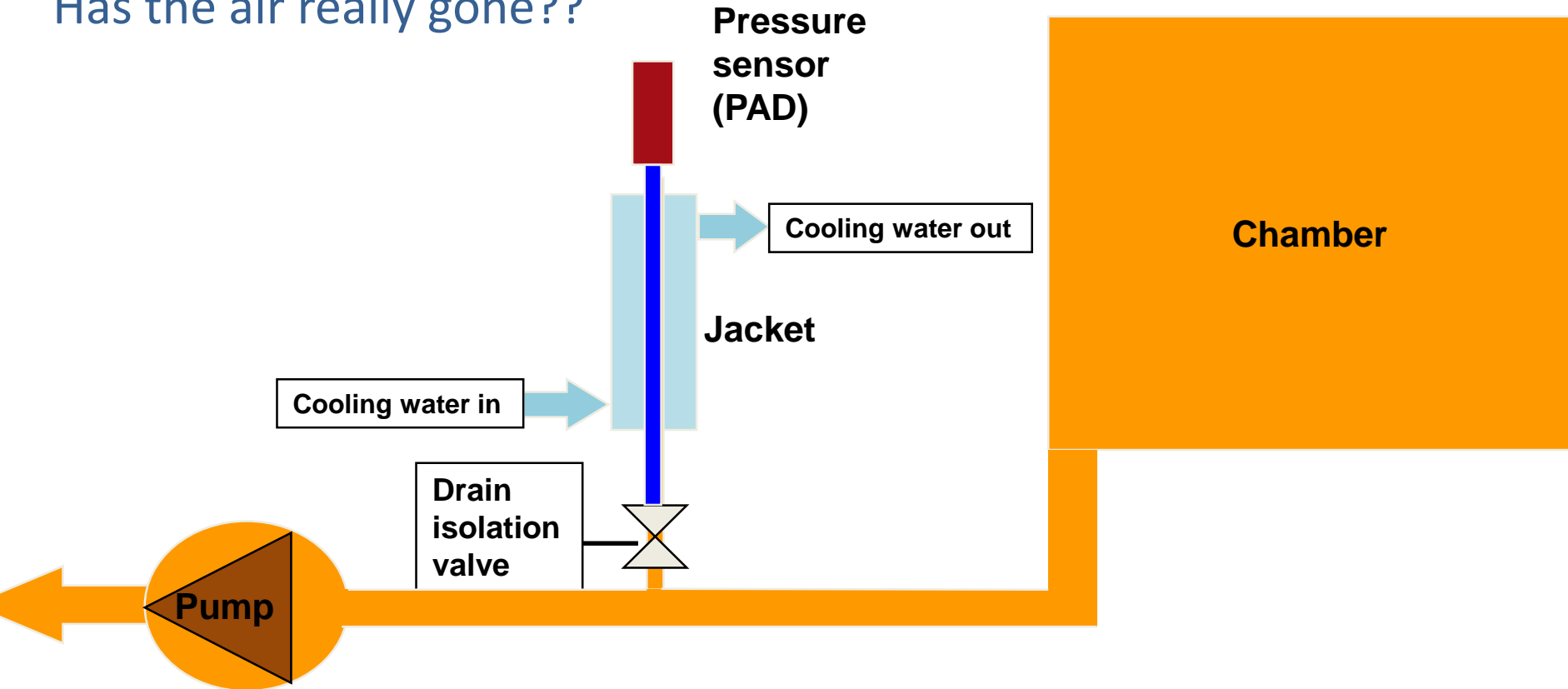

Steam pulsed air removal – Air Detection

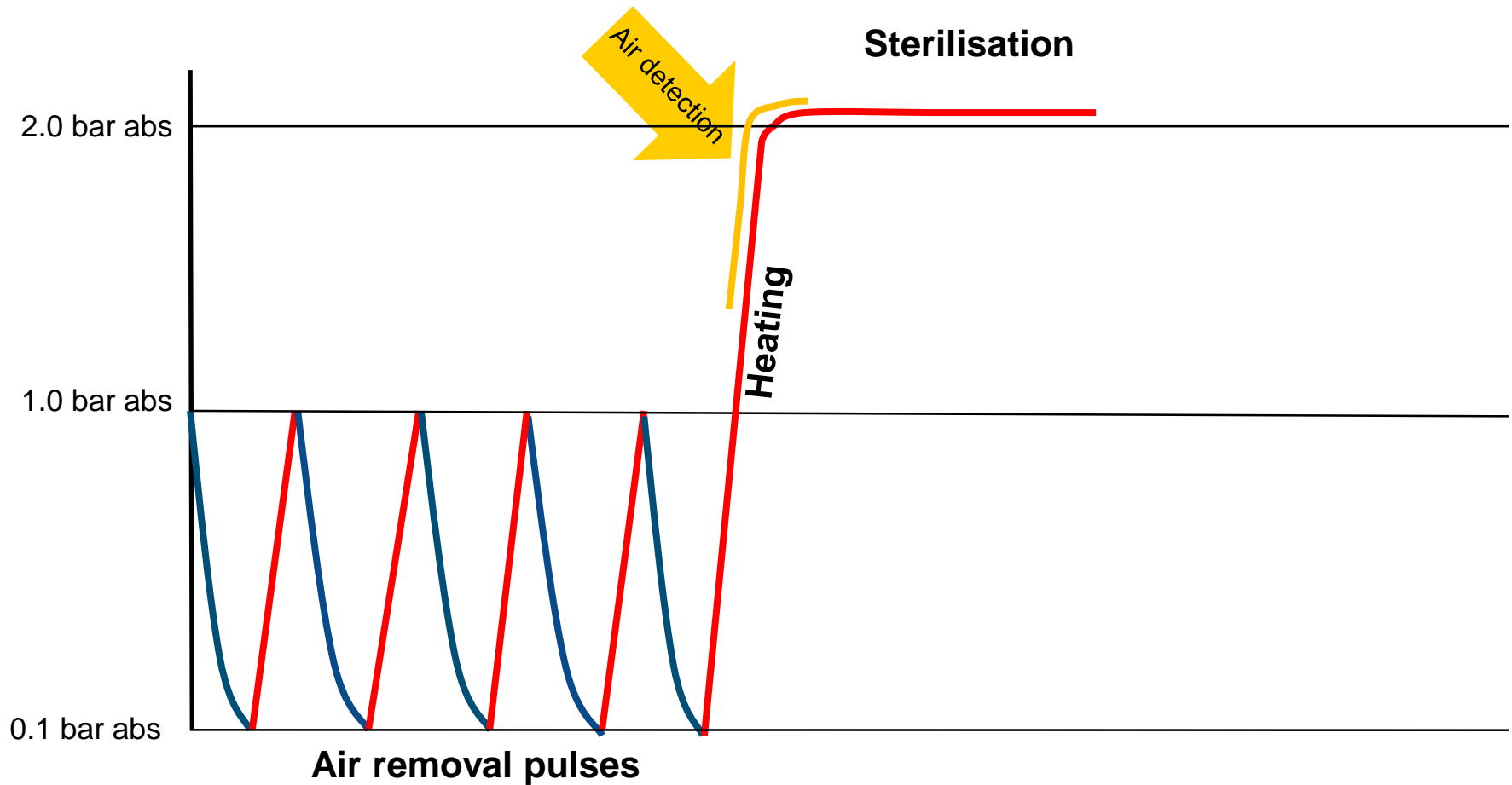

Steam pulsed air removal – Air Detection (neg/pos pulses)

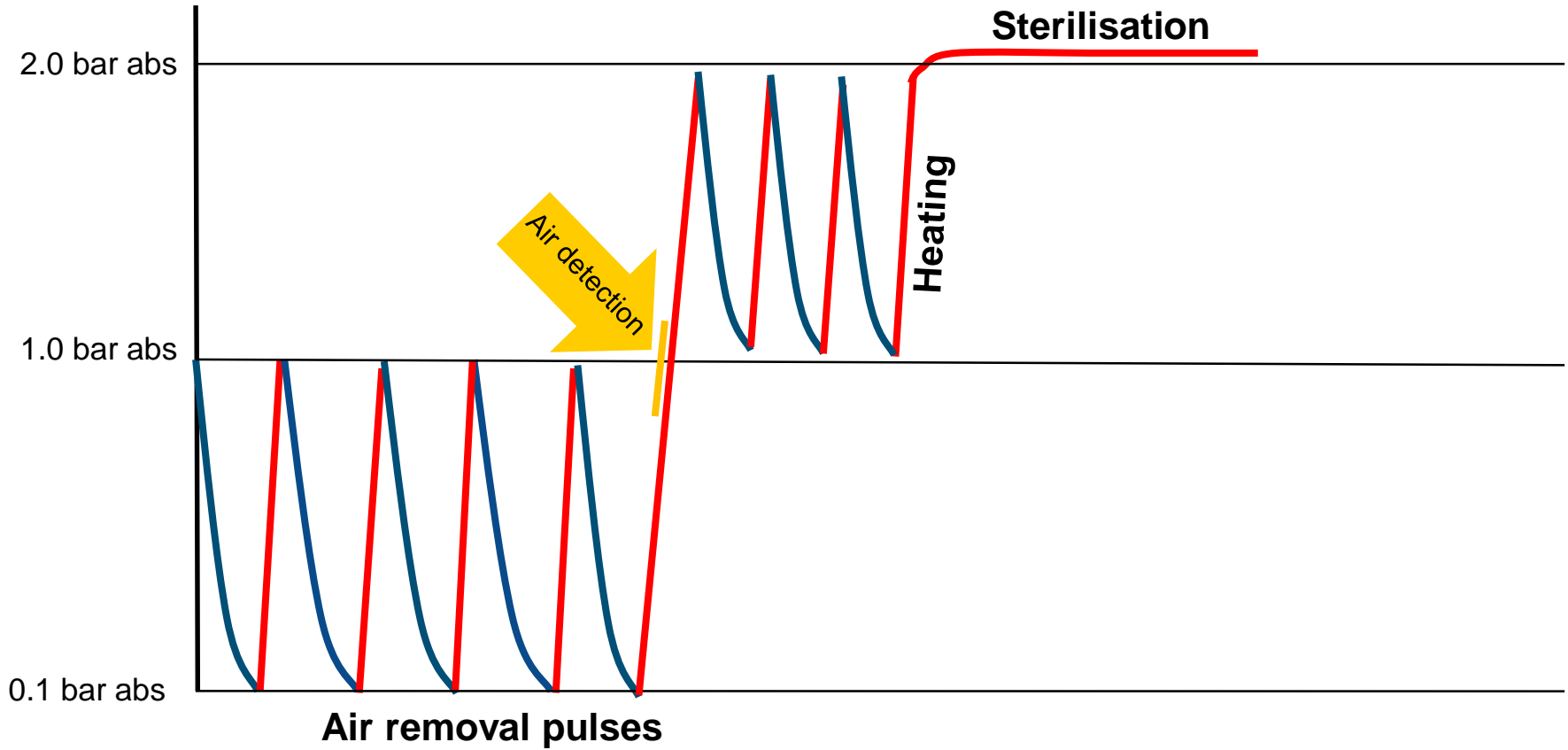

Standard cycle: Process phases (saturated steam)

1. Preheating with hot air (usually for loads very hard to dry) or other auxiliary treatments
2. Air removal from the chamber (e.g. By vacuum)
3. Heating and Sterilization

Standard cycle: Process phases (saturated steam)

- Steam is fed rapidly into the chamber until the sterilization temperature is reached.
- Temperature equilibration/penetration time: delay between temperature of the product and the temperature of the chamber.
- Condensate is continuously removed by a dynamic steam: the vacuum pump always extracts condensate through a small valve
 - Fresh Vapour continuously replaces the condensed steam 😊
 - Expectations are excellent stability and uniformity of temperature inside the chamber 😊

Standard cycle: Process phases (saturated steam)

1. Preheating with hot air (usually for loads very hard to dry) or other auxiliary treatments
2. Air removal from the chamber (e.g. By vacuum)
3. Heating and Sterilization
4. Post Sterilization phases (drying and/or cooling)

Standard cycle: Process phases (saturated steam)

The selection for this stage of the process depends on the load type and on the final acceptance criteria: -

- Dry product – but how dry?
- Wet product – does it have to be dry?
- Cooling requirements – fluid load?

Drying stage

Drying and 'natural' cooling by final vacuum:

Once the sterilization phase ends, the vacuum pump is used to pull a deep vacuum.

By creating a vacuum in the chamber, we are able to lower the boiling point of water, in doing so and considering the load is hot following the sterilization phase, we are able to create a temperature differential between the boiling point of water and the load item.

Drying stage

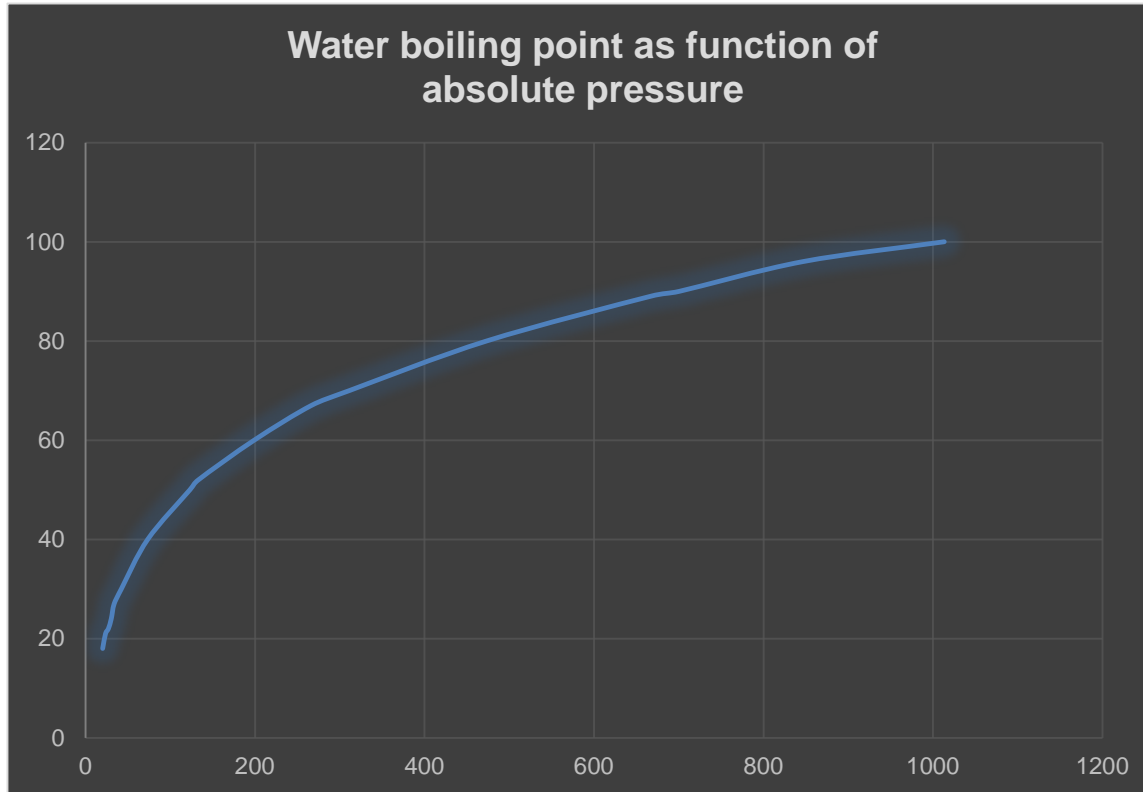

mbara	degC
1013.3	100
846.6	96
700.6	90
666.6	89
473.4	80
311.5	70
266.6	67
199.1	60
133.3	52
123.3	50
73.48	40
42.33	30
33.86	27
30.48	24
27.09	22
23.71	21
20.32	18

Drying stage

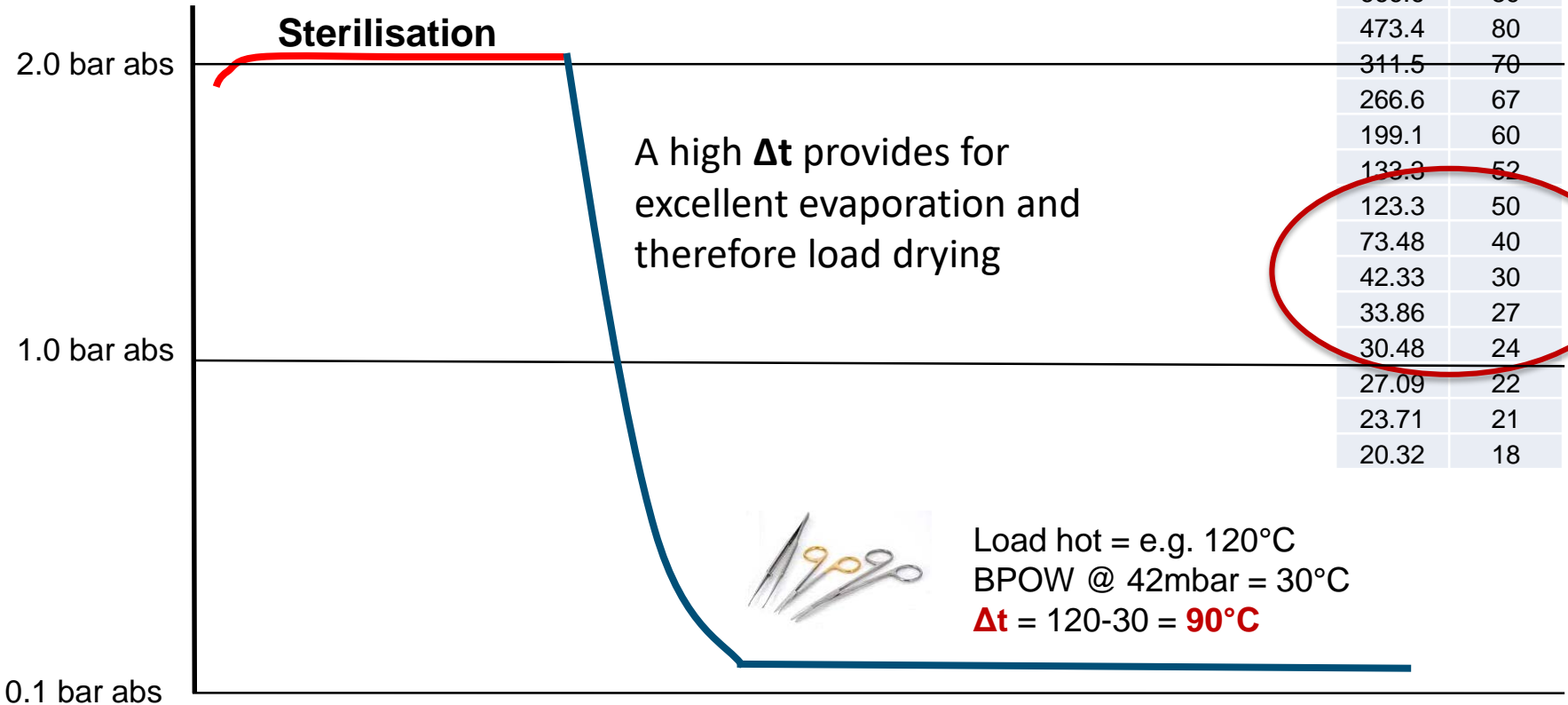

Drying stage

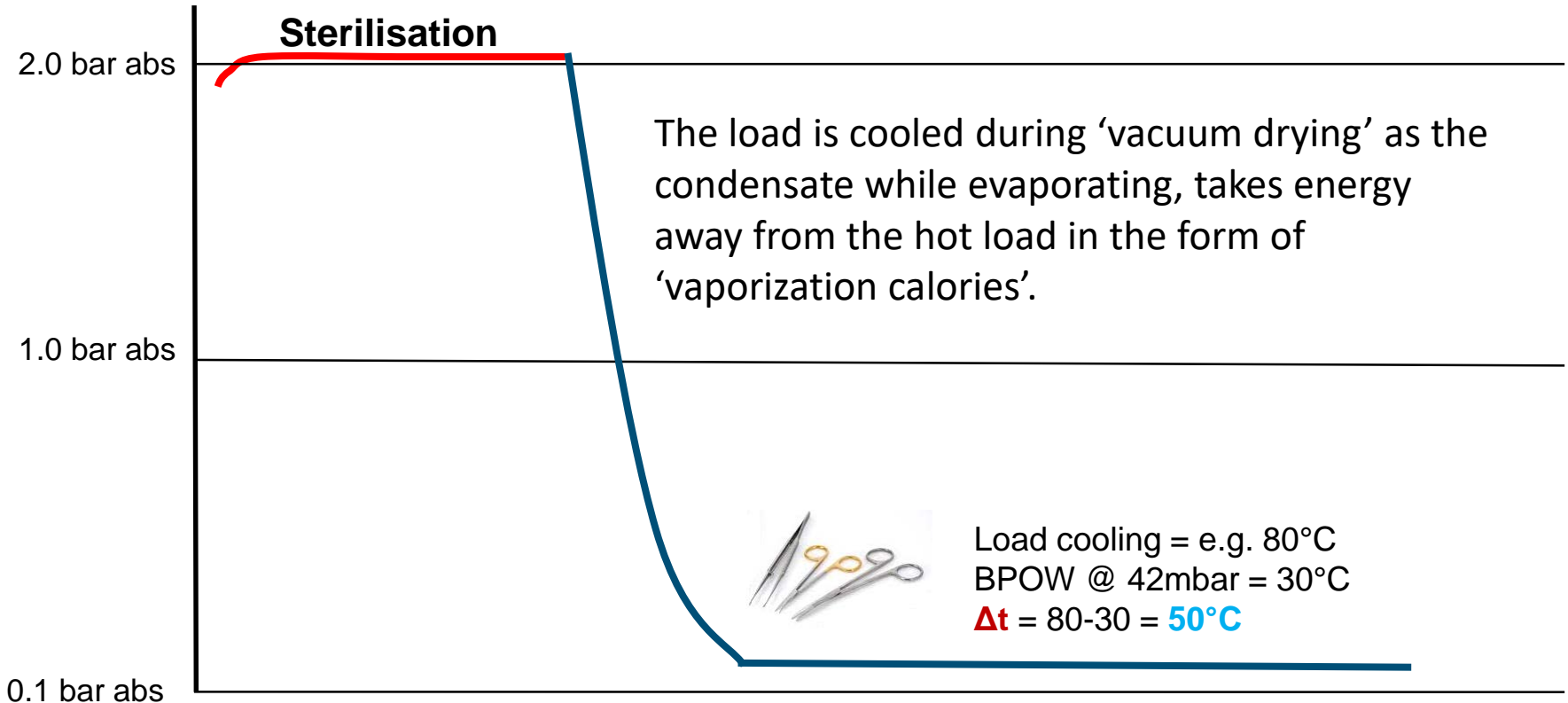

Drying stage

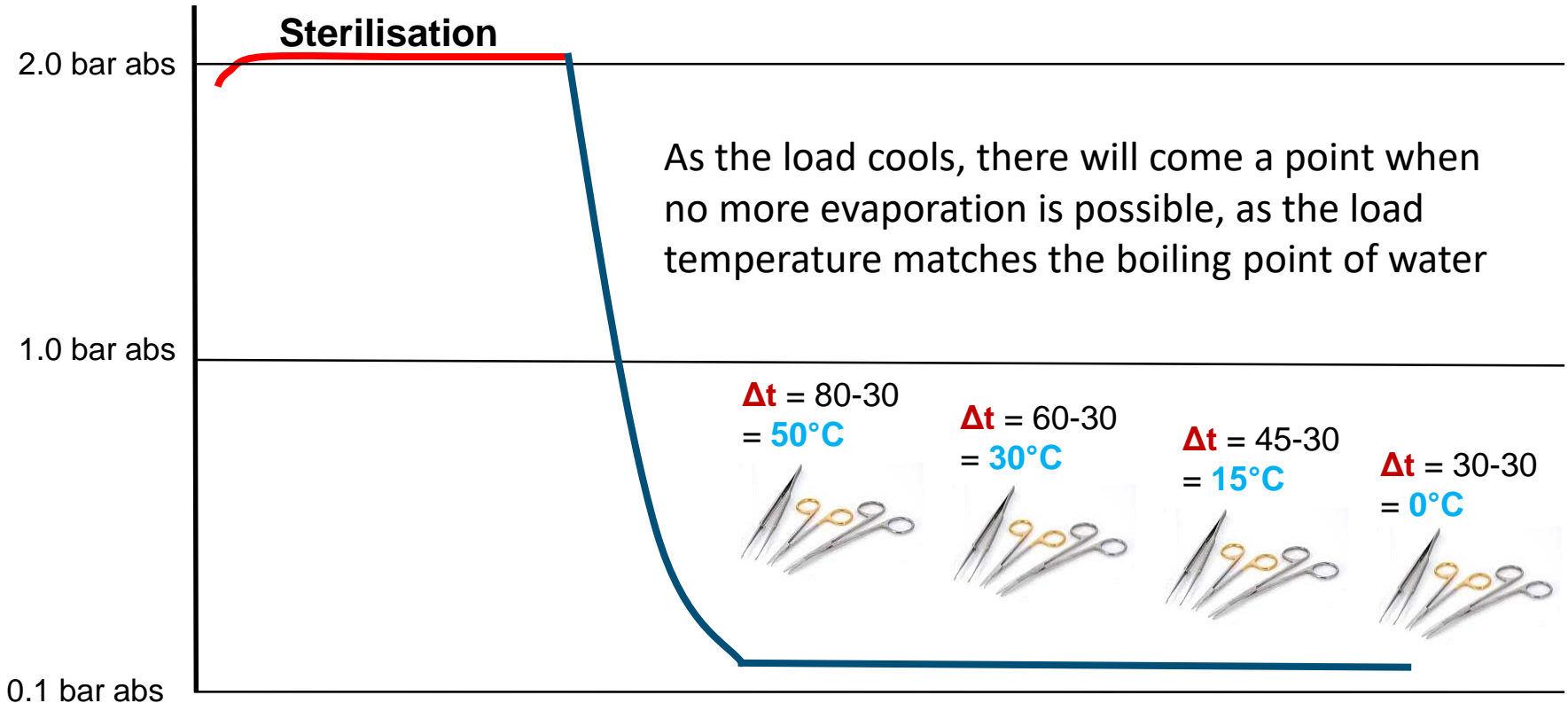

Drying stage

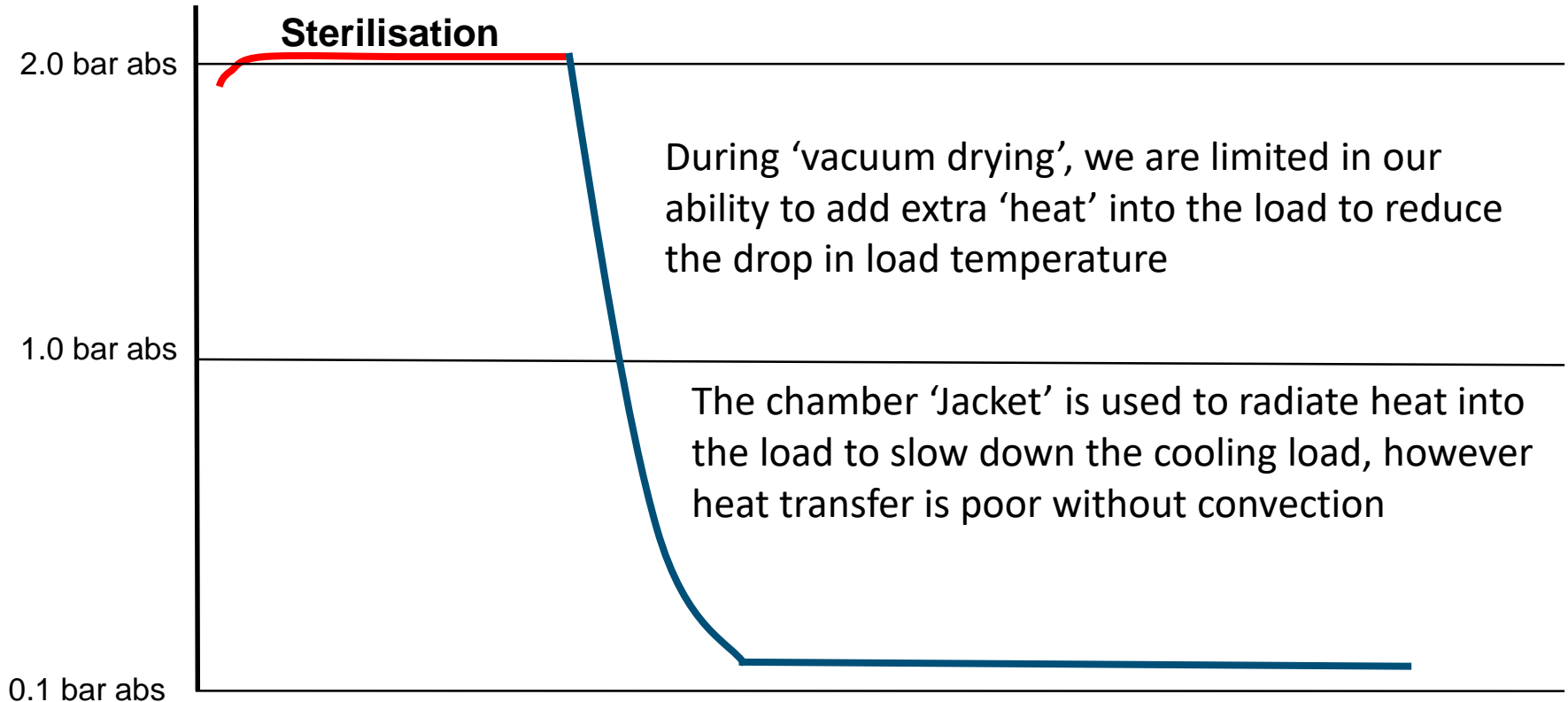

Drying stage

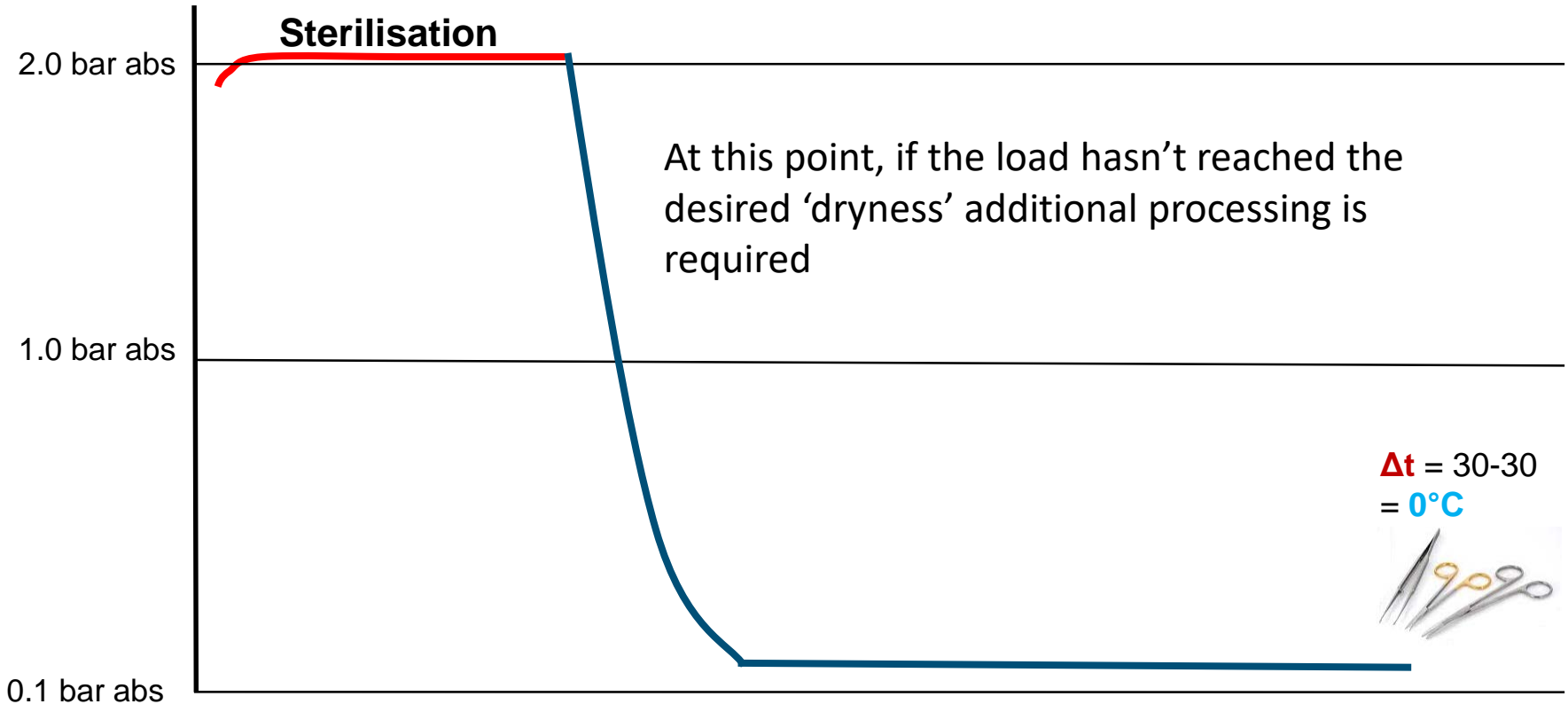

Drying stage – Air Pulses

Due to the absence of air in the chamber, heat transfer from the heated jacket is poor due to the lack of convection.

By injecting air into the chamber we are able to improve the heat transfer capability of the process, i.e. utilise convection from the hot chamber walls (jacket) to the load.

This has the effect of re-heating the load, so that during the vacuum stage of the air pulses we again have a positive Δt and therefore further evaporation

Drying stage – Air Pulses

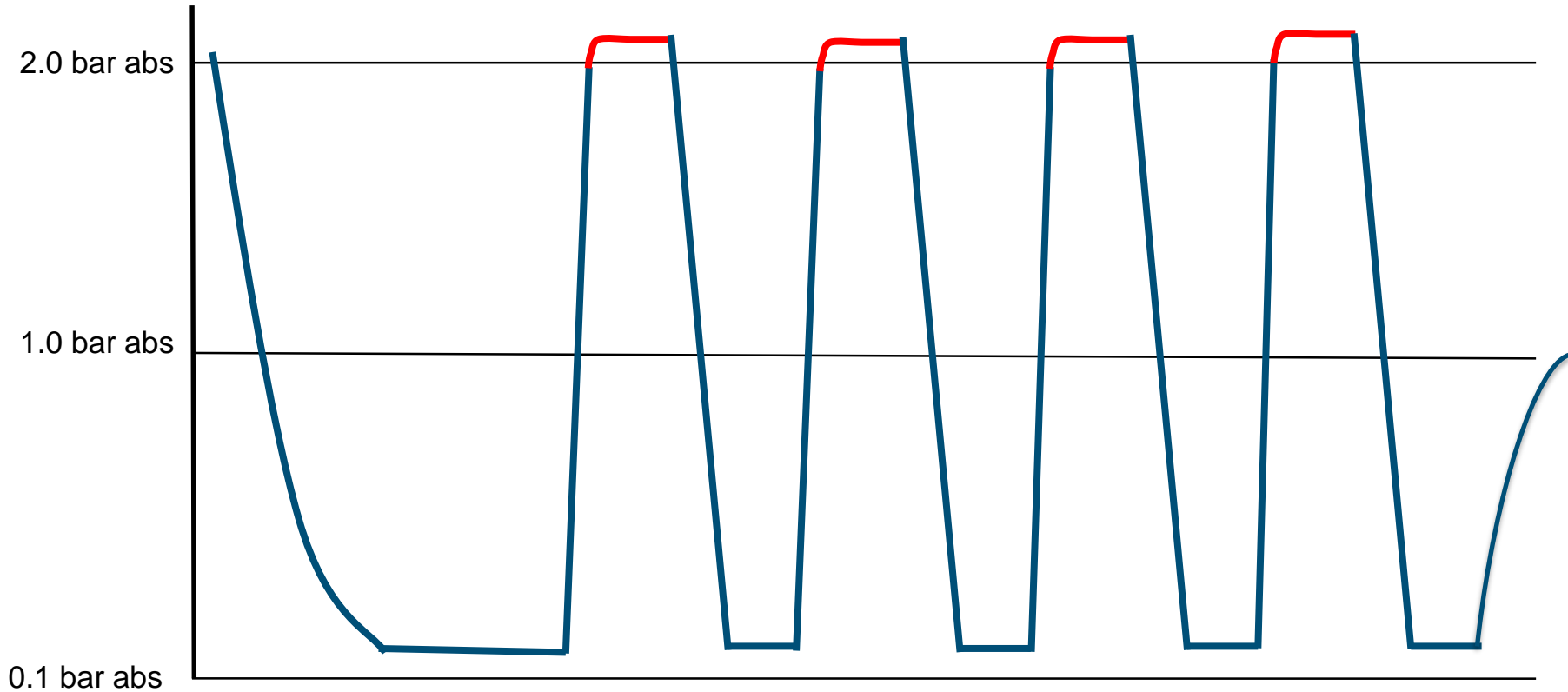

Drying stage – Air Pulses

As the load cools, convection re-heats the load allowing further evaporation

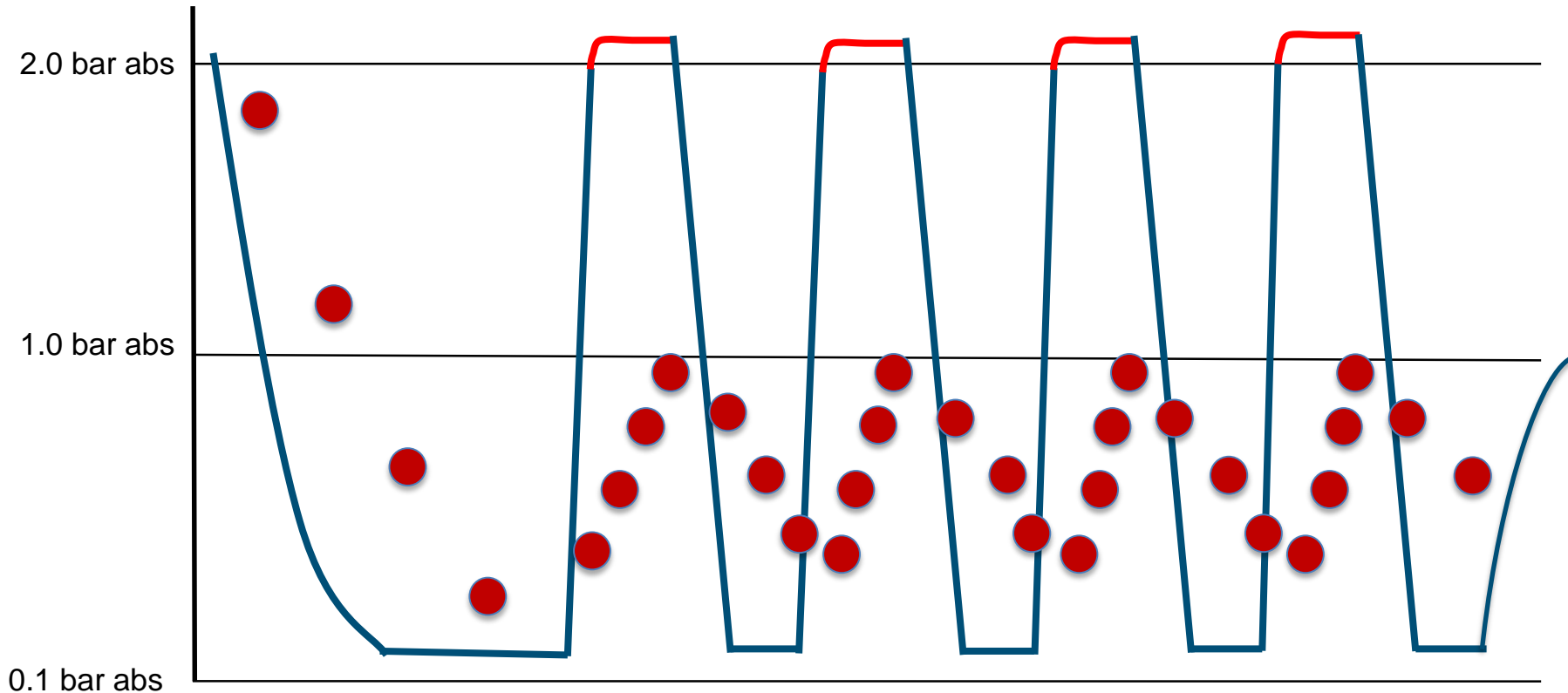

As ‘Stopper’ loads are often used in containers that required a very low moisture content, e.g. Lyophilization, the regular ‘vacuum drying’ is often insufficient to achieve the desired moisture content, in this case ‘pulsed air drying’ is routinely used.

In addition to ‘pulsed air drying’, it’s advantageous to heat the air before it enters the chamber, otherwise a period of time is required to heat the air itself before it can heat the load.

In addition to ‘pulsed air drying’, and to minimise condensate formation in the load prior to the sterilization phase, it’s typical to use a ‘pre-heating’ phase prior to pulsed air removal, this reduces condensate formation in the stopper bags and improve the efficiency of the drying stage later in the process.

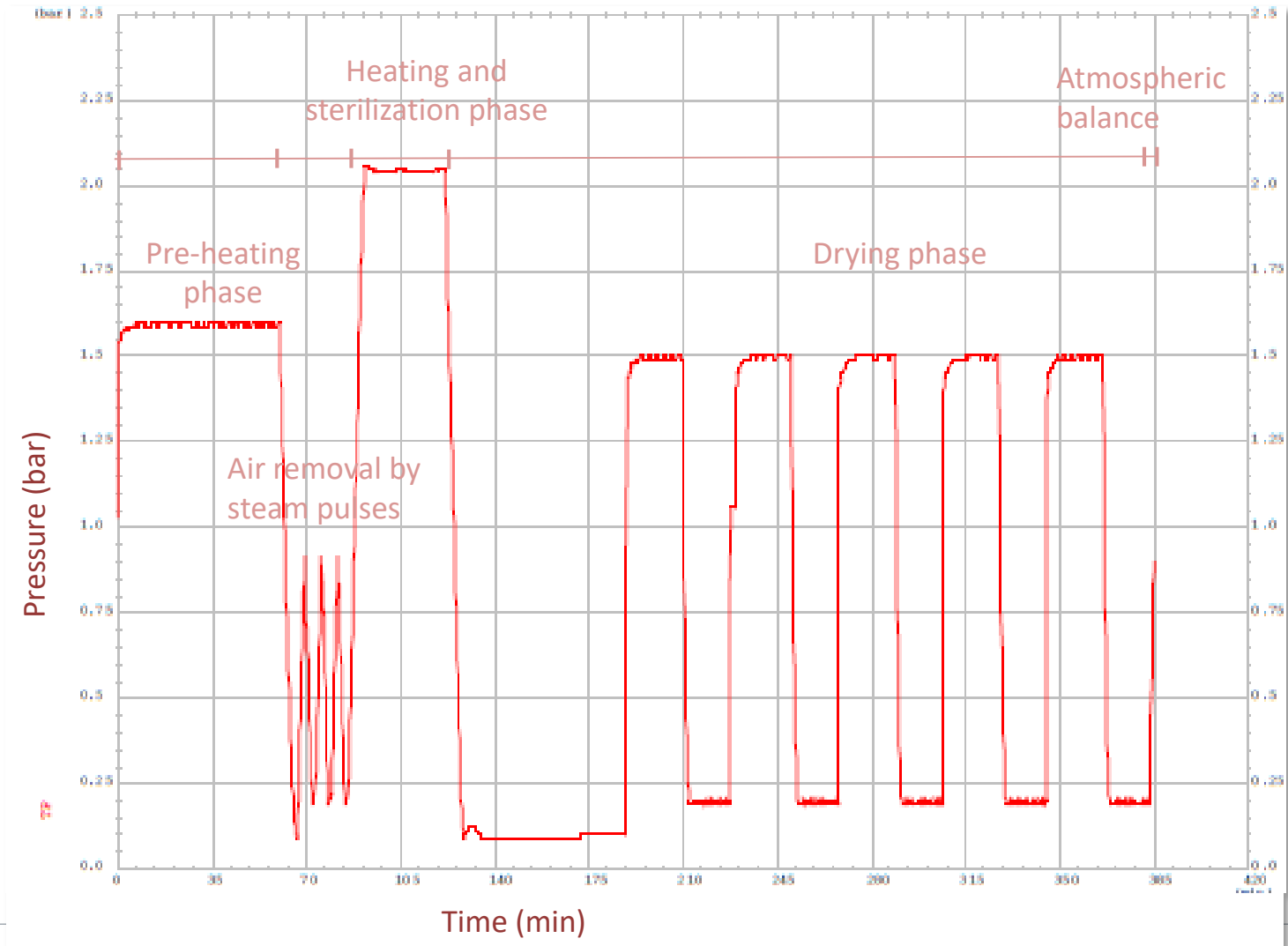

Gravimetric method to determine RH

Load cell Gibertini

Stoppers are weighed before and after a specific drying procedure at a defined temperature.



Gravimetric method to determine RH

Weight of the samples after the drying procedure in the load cell (heated up to 120°C)

Residual Humidity (%)

$$= \frac{\text{Wet weight} - \text{dried weight}}{\text{Wet weight}} \times 100$$

Samples weight before heating procedure (after sterilization treatment)

Gravimetric method to determine RH

Our results after cycle optimization...



Drying phase	Cycle time	Residual Humidity [%]
Jacket (steam) + hot air	298 min	0,228
Jacket (steam) + hot air + FAN	291 min	0,015

+ FAN
+ FAN

Solid load drying: key points

- Material design and packaging system
- Item orientation/arrangement
- Drying by vacuum improved by: -
 - Auxiliary heating equipment
 - Vacuum/hot air pulses
 - Forced circulation of hot air (with fan)



Stoppers in bags			SINGLE BAG	DOUBLE BAG
AUTOCLAVE EQUIPMENT			CYCLE TIME	RESIDUAL HUMIDITY
FAN	JACKET	HOT AIR DRYING		
			298'	0,23%
			291'	0,01%
			353'	0,08%
			322'	0,07%

Compared to LVP, they are more resistant to pressure differences: the resistance decreases as the diameter increases



Cooling method: **vacuum**

PHASE LISTS

n. phase

1	PREPARE AUTOCLAVE	
2	DEPRESSURIZE BY VACUUM PUMP	
3	TIMED VACUUM, STEAM INJECTION	
4	HEATING	41
5	STERILIZATION	41
6	DEPRESSURIZE BY VACUUM PUMP	9
7	TIMED VACUUM	21
8	RETURN TO ATMOSPHERIC PRESSURE	137
9	CYCLE END	148
10	EMERGENCY	156

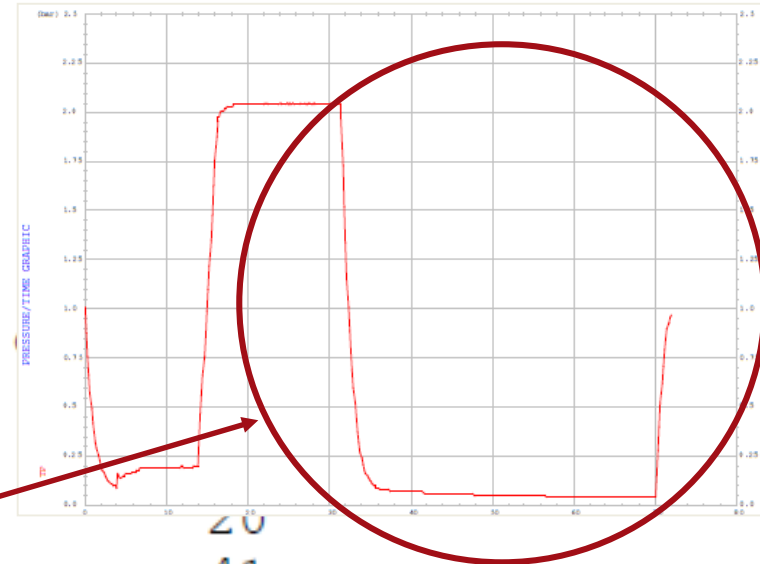

What are the other options to perform the cooling ?



Indirect cooling

by cold water circulation in the jacket and/or in plates with air counterpressure



Direct cooling

by water spray with air counterpressure

The choice depends on customer needs!!
(i.e. cycle time, final unloading temperature,
product unloaded wet or dry)

Thank you.