



# Test Methods for Prefilled Syringes

Horst Koller, CEO, HK Packaging Consulting GmbH

Roman Mathaes PhD, Senior Group Leader, Lonza Drug Product Services

- Luer Cone & Luer Lock Compliance Testing**

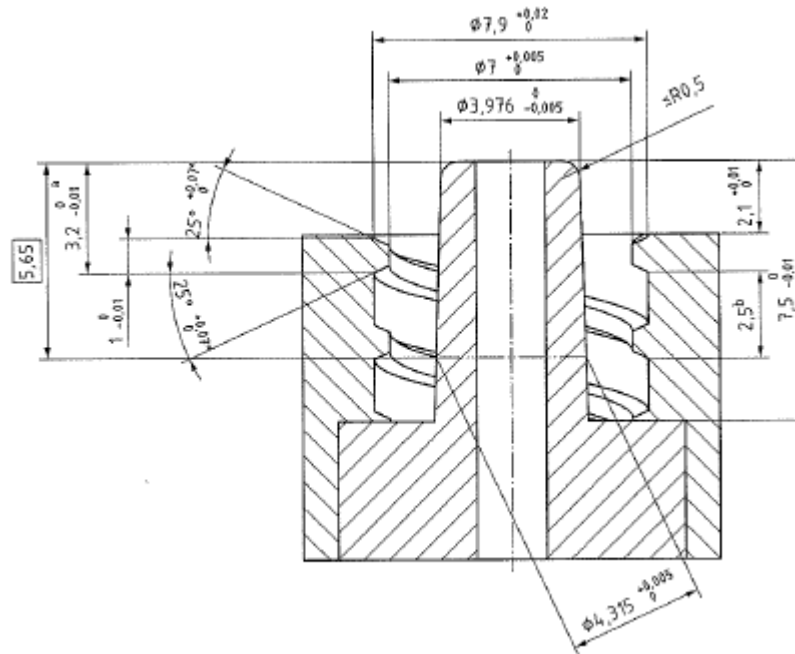

Prefilled Syringes

# Standards for Luer Cone & Luer Lock Compliance

## **ISO 80369-7 (TC 210)**

**Small-bore connectors for liquids and gases in healthcare applications**

**Part 7: Connector for intravascular or hypodermic applications**

## **ISO 80369-20 (TC 210)**

**Small-bore connectors for liquids and gases in healthcare applications**

**Part 20: Common test methods**

## **ISO 11040-4 (TC 76)**

**Prefilled Syringes**

**Part 4: Glass barrels for injectables and sterile subassembled syringes ready for filling**

## **ISO 11040-6 (TC 76)**

**Prefilled Syringes**

**Part 6: Plastic barrels for injectables and sterile subassembled syringes ready for filling**

# Standards for Luer Cone & Luer Lock Compliance

## ISO 80369-7

Small-bore connectors for liquids and gases in healthcare applications

Part 7: Connector for intravascular or hypodermic applications

(TC 210)

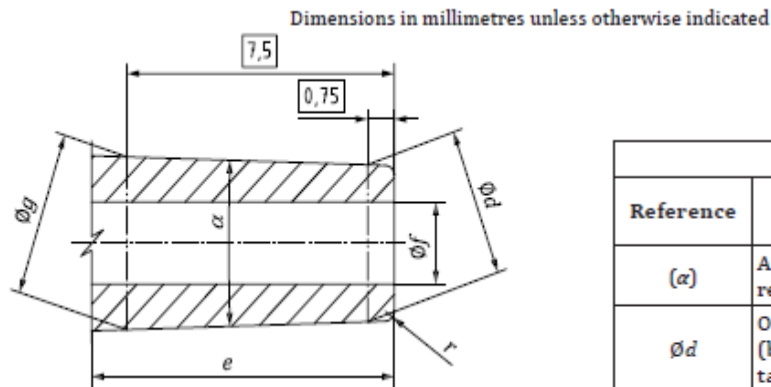

Dimensions in millimetres unless otherwise indicated

Male LUER SLIP CONNECTOR (L1)				
Reference	Designation	Dimension		
		Minimum	Nominal	Maximum
( $\alpha$ )	Angle of the taper (6 % taper nominal) (degrees, reference)	—	(3,44°)	—
$\varnothing d$	Inside diameter at the tip of the male taper at 0,750 (basic dimension) from the tip (small end) of the male taper	3,970	4,021	4,072
$e$	Length of the male taper <sup>a</sup>	7,500	8,400	10,500
$\varnothing f$	Inside diameter at the tip of the male taper	—	2,100	2,900
$\varnothing g$	Outside diameter of the larger end of the male taper at 7,500 (basic dimension) from the tip (small end) of the male taper	4,376	4,426	4,476
$r$	Radius or chamfer at the outside tip of the male taper	0,000	0,250	0,500

<sup>a</sup> This dimension also defines the extent of the CONNECTOR. MEDICAL DEVICE features beyond the CONNECTOR may require evaluation to ISO 80369-1:2010, Annex B, to ensure NON-INTERCONNECTABLE characteristics.

# Standards for Luer Cone & Luer Lock Compliance

ISO 80369-7

Small-bore connectors for liquids and gases in healthcare applications

Part 7: Connector for intravascular or hypodermic applications

(TC 210)

Figure C.5 — Female reference LUER SLIP CONNECTOR for testing male LUER CONNECTORS for leakage, separation from axial load, stress cracking and NON-INTERCONNECTABLE characteristics

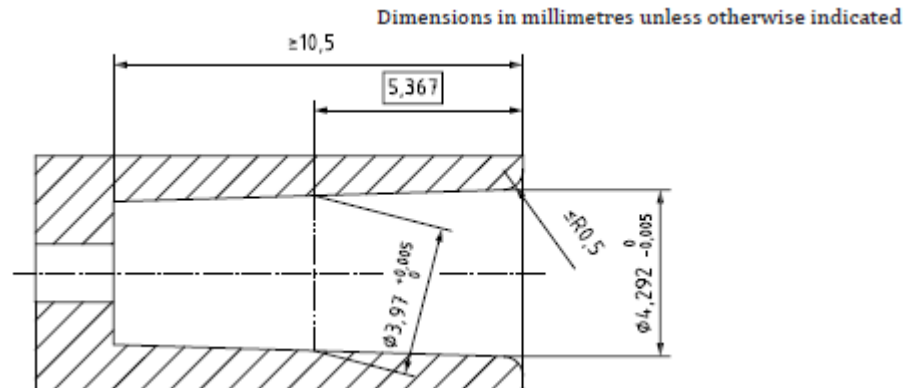

# Standards for Luer Cone & Luer Lock Compliance

ISO 80369-20

Small-bore connectors for liquids and gases in healthcare applications

Part 20: Common test methods

(TC 210)

Table 1 — TEST METHODS and corresponding Annex of this part of ISO 80369

Test method	Annex
Leakage by pressure decay	<a href="#">Annex B</a>
Positive pressure liquid leakage	<a href="#">Annex C</a>
Subatmospheric-pressure air leakage	<a href="#">Annex D</a>
Stress cracking	<a href="#">Annex E</a>
Resistance to separation from axial load	<a href="#">Annex F</a>
Resistance to separation from unscrewing	<a href="#">Annex G</a>
Resistance to overriding	<a href="#">Annex H</a>
Disconnection by unscrewing	<a href="#">Annex I</a>
Modification of the TEST METHODS to generate variable data for statistical analysis	<a href="#">Annex J</a>
NOTE MANUFACTURERS can use the modified TEST METHODS of <a href="#">Annex J</a> .	

# Standards for Luer Cone & Luer Lock Compliance

ISO 80369-20

Small-bore connectors for liquids and gases in healthcare applications

Part 20: Common test methods

(TC 210)

Table 1 — TEST METHODS and corresponding Annex of this part of ISO 80369

Test method	Annex
Leakage by pressure decay	<a href="#">Annex B</a>
Positive pressure liquid leakage	<a href="#">Annex C</a>
Subatmospheric-pressure air leakage	<a href="#">Annex D</a>
Stress cracking	<a href="#">Annex E</a>
Resistance to separation from axial load	<a href="#">Annex F</a>
Resistance to separation from unscrewing	<a href="#">Annex G</a>
Resistance to overriding	<a href="#">Annex H</a>
Disconnection by unscrewing	<a href="#">Annex I</a>
Modification of the TEST METHODS to generate variable data for statistical analysis	<a href="#">Annex J</a>
NOTE MANUFACTURERS can use the modified TEST METHODS of <a href="#">Annex J</a> .	

# Standards for Luer Cone & Luer Lock Compliance

ISO 80369-20

Small-bore connectors for liquids and gases in healthcare applications

Part 20: Common test methods

(TC 210)

Annex C  
(normative)

## Falling drop positive-pressure liquid leakage TEST METHOD

### C.3 Apparatus

- a) the male or female CONNECTOR under test;
- b) the appropriate reference CONNECTOR, as specified in the relevant APPLICATION part of ISO 80369 for the leakage TEST METHOD, to be assembled to the CONNECTOR under test;
- c) a means to simultaneously apply an axial force of 27,5 N and torque of 0,12 N·m, or more if required by the relevant APPLICATION part of ISO 80369;
- d) a means to contain and pressurize water to the specified test pressure. Rigid fixtures and apparatus materials (such as metal) should be used to avoid inaccurate test results;

### C.4 Procedure

- a) Assemble the CONNECTOR under test to the appropriate male or female reference CONNECTOR, both CONNECTORS being dry.
- b) For a non-locking (slip) CONNECTOR, assemble by applying an axial force of between 26,5 N and 27,5 N for 5 s to 6 s while rotating the CONNECTOR under test to a torque of between 0,08 N·m and 0,10 N·m and a rotation not exceeding 90°.
- i) Visually inspect for a falling drop of water from the CONNECTION during the specified hold period.



# Standards for Luer Cone & Luer Lock Compliance

## ISO 11040-4 and ISO 80369-7 Relationship

### ISO 11040-4

#### 2 Normative references

The following documents, in whole or in part, are normatively referenced in this document and are indispensable for its application. For dated references, only the edition cited applies. For undated references, the latest edition of the referenced document (including any amendments) applies.

ISO 594-1,<sup>1)</sup> Conical fittings with a 6 % (Luer) taper for syringes, needles and certain other medical equipment — Part 1: General requirements

ISO 594-2,<sup>1)</sup> Conical fittings with 6 % (Luer) taper for syringes, needles and certain other medical equipment — Part 2: Lock fittings

1) ISO 594-1 and ISO 594-2 will be replaced by ISO 80369-7 (currently in preparation by ISO/TC 210).

**NOTE** Commercially developed glass Luer cone and Luer lock prefilled syringes routinely mate with Luer devices in order to effectively administer the medication stored within the syringe. Examples are disposable needles, needleless connector devices, and other forms of Luer access. The current state of the art syringe tip glass forming technology for manufacturing glass prefilled syringes cannot conform completely to the standards on Luer connectors (see ISO 594 series). The ISO 594 series has been developed using ground glass, metal, and injection moulded technology, as well as plastic resins, as the baseline rationale for compliance and capabilities.

Differences in the manufacturing methodologies and the need for expanded tolerances in the glass forming manufacturing process are acknowledged. This is why dimensional tolerances are different. While these tolerances are outside of the range of ISO 594 with respect to some of the dimensions, the glass formed tip does successfully mate with the injection moulded female counterparts. See [5.2](#) and ISO 594:1986 for functional test methods that accommodate for the formed tip manufacturing process.

Luer tip dimensions mentioned in the following figures can be checked by means of camera measurements or indirectly by using a gauge similar to the one described in ISO 594.

# Standards for Luer Cone & Luer Lock Compliance

## ISO 11040-4 and ISO 80369-7 Relationship

### ISO 80369-7

Commercially developed glass prefilled syringes routinely mate with LUER CONNECTOR equipped MEDICAL DEVICES in order to effectively administer the medication stored within the syringe. Examples: disposable needles, needless ports and other forms of luer access. Current state-of-technology syringe tip glass forming technology for manufacturing glass prefilled syringes cannot conform completely to either previous Luer fitting standard, ISO 594 or this International Standard. Both the previous standard and this standard have been developed using ground glass, metal and injection moulded technology and plastic resins as the baseline for compliance and capabilities.

The committee acknowledges the differences in the manufacturing methodologies and the need for expanded tolerances in the glass forming manufacturing process. The baseline specifications of the tapered tip need to remain similar. However to accommodate the glass forming manufacturing process, there needs to be expanded dimensional tolerances. While these tolerances are outside of the range of this International Standard with respect to some of the dimensions, a glass formed tip does successfully mate with the injection moulded female LUER CONNECTORS. Refer to ISO 11040-4 [7] for a listing of those critical dimensions, their expanded corresponding tolerances and functional test methods that accommodate the formed tip manufacturing process.

### ISO 11040-4

#### 5.2 Functional testing of Luer connection

The functional performance of the glass prefilled syringe barrel with regard to the conical connection to a 6 % Luer female connector fitting shall be demonstrated through performance testing with female reference connectors made of plastic instead of steel.

**NOTE** The forming process of glass prefillable syringes results in a "wavy" Luer connector surface finish that is incompatible with the use of steel reference connectors for liquid and air leakage, separation force, and unscrewing torque type tests. In addition, male Luer connectors of glass prefillable syringes are often roughened on customer request.

For the purpose of demonstrating the functional performance of the syringe Luer connection and the equivalent safety of the connection, the plastic reference connectors shall be verified for compliance with the dimensional requirements of ISO 594-1.

The selected plastic material for the reference connectors shall be chosen for being representative for the normal clinical conditions of use. A rationale shall be developed for the selection of material(s).

# Standards for Luer Cone & Luer Lock Compliance

11040-6

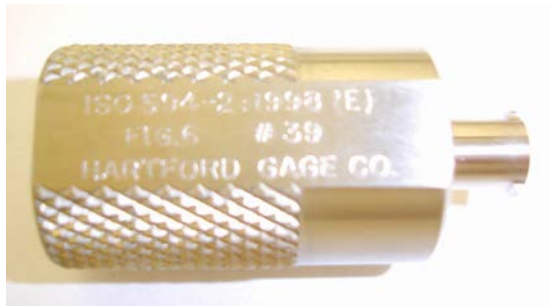

11040-4

SIZES	CLEAR COLOR CODE		color code
	LENGTH OF THE CANNULA		
30G			light yellow
26G			brown
25G			orange
24G			purple
23G			blue
22G			black
21G			green
20G			yellow
19G			creamy yellow
18G			pink
16G			white
NOTE Length scope: 3/8" - 1 1/2" (12mm - 38mm)			

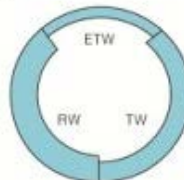

can choose RW, TW and ETW.

Thank You !  
QUESTIONS ?