

# Mass Extraction Technology for Pharmaceutical Packaging CCIT

**Instructor:**

- ***Lukas Engel; Pfeiffer Vacuum; Lukas.engel@pfeiffer-vacuum.com  
Market Manager Pharma CCIT & Medical Leak Testing***



## Structure

- What is Mass Extraction?
  - How it works / How it looks
- Application Cases:
  - #1: ASTM Standard
  - #2: Autoinjector
  - #3: Flexible Bags
  - #4: Comparative Study
- Summary



# Mass Transfer Across Package

## MASS EXTRACTION

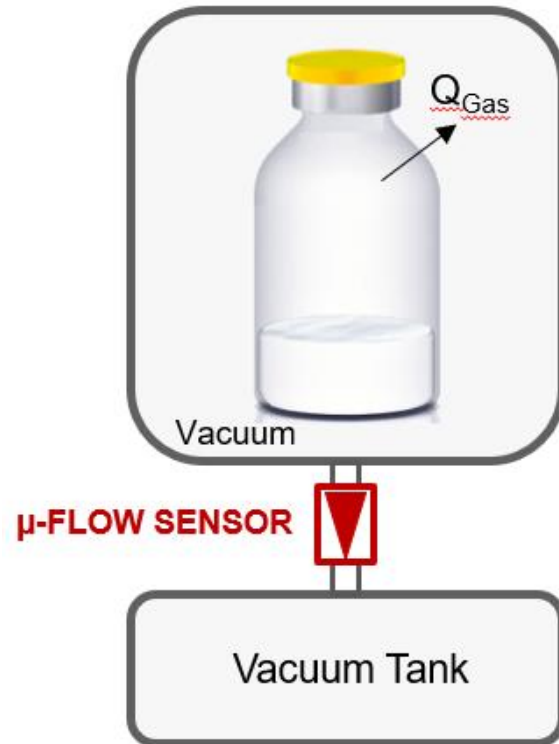

## HELIUM MASS SPECTROMETRY

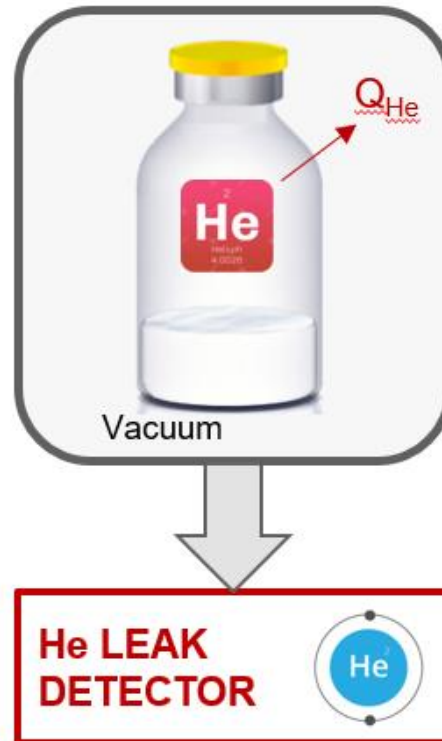

## OPTICAL EMISSION SPECTROMETRY

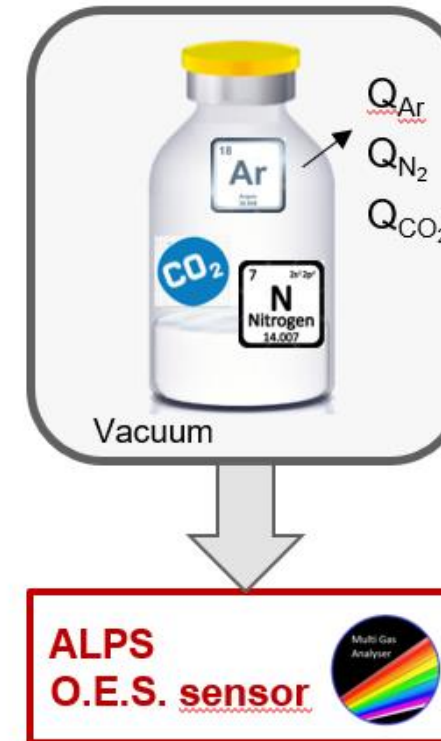

# Mass Transfer Across Package

## MASS EXTRACTION

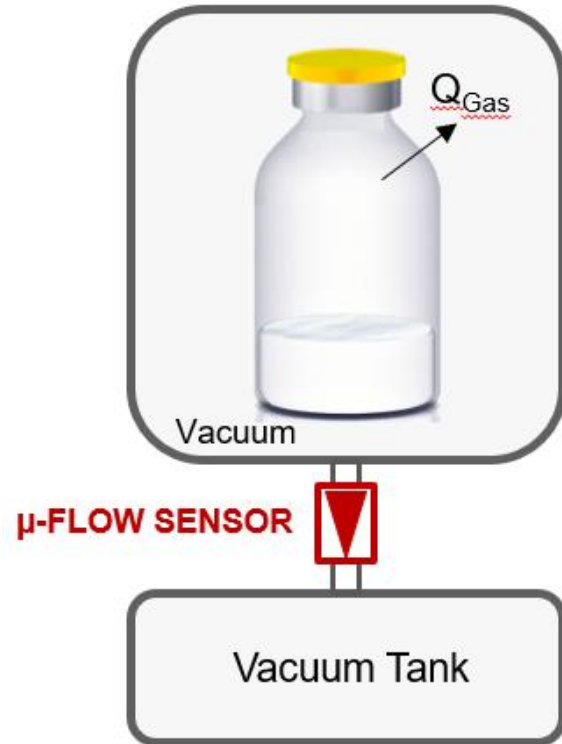

Air Leak :  
1-2 $\mu$ m

Air Leak :  
1-2 $\mu$ m

Water Leak\* :  
1-2 $\mu$ m

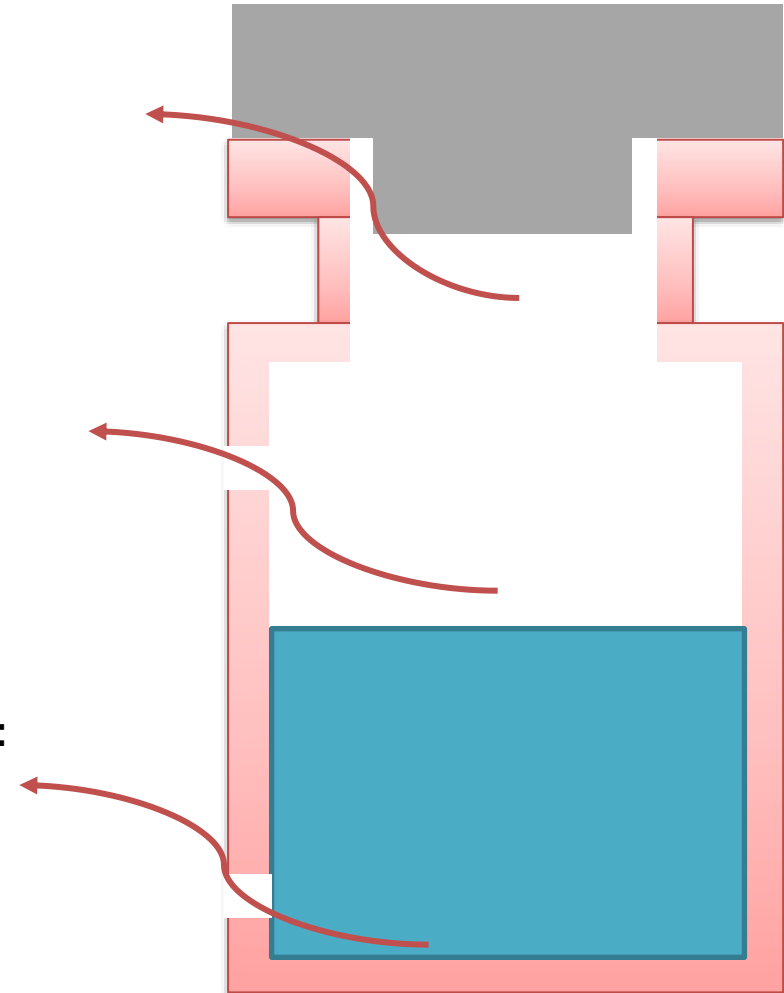

\*There might be a risk of (partial) clogging depending on the drug (high protein)

# What is Mass Extraction?

# Mass Extraction

**Add the following:**

## ■ <1207.2> PACKAGE INTEGRITY LEAK TEST TECHNOLOGIES

- 1. INTRODUCTION
- 2. DETERMINISTIC LEAK TEST TECHNOLOGIES
  - 2.1 Electrical Conductivity and Capacitance (High-Voltage Leak Detection)
  - 2.2 Laser-Based Gas Headspace Analysis
  - 2.3 Mass Extraction
  - 2.4 Pressure Decay
  - 2.5 Tracer Gas Detection, Vacuum Mode
  - 2.6 Vacuum Decay
- 3. PROBABILISTIC LEAK TEST TECHNOLOGIES

**Table 1. Deterministic Leak Test Technologies<sup>a</sup>**

Deterministic Leak Test Technologies	Package Content Requirements	Package Requirements	Leak Detection Limit <sup>b</sup>	Measurement Outcome and Data Analysis	Effect of Method on Package	Test Time Order of Magnitude
Mass extraction	Gas or liquid must be present at leak site. Presence of liquid at leak site requires test pressures below vapor pressure. Product must not clog leak path.	Rigid, or flexible with package restraint mechanism.	Row 3 Varies with product-package, instrument, test fixtures/chamber, and method parameters.	Quantitative measure of mass flow rate resulting from test sample headspace escape or liquid product volatilization within an evacuated test chamber housing the test sample. Quantitative pressure readings early in the test cycle indicate larger leak presence. Whole test sample leakage rate is determined by comparing the test sample mass flow results to results using leak rate standards and positive controls.	Nondestructive	Seconds to minutes

## How it works

Measurement of the **mass flow** rate ( $\mu\text{g}/\text{min}$  or  $\text{scc}/\text{sec}$ ) from a Closed Container in a vacuum chamber to **quantify and detect** the presence of leaks equal to or larger than maximum allowed value/defect (**down to  $1\mu\text{m}$** ).

The measured medium is gaseous:

- Air/Nitrogen
- At vacuum (for liquid filled containers: under the boiling point of water at room temperature  $\sim 18$  torr / 24 mbar)  $\rightarrow$  water vapor

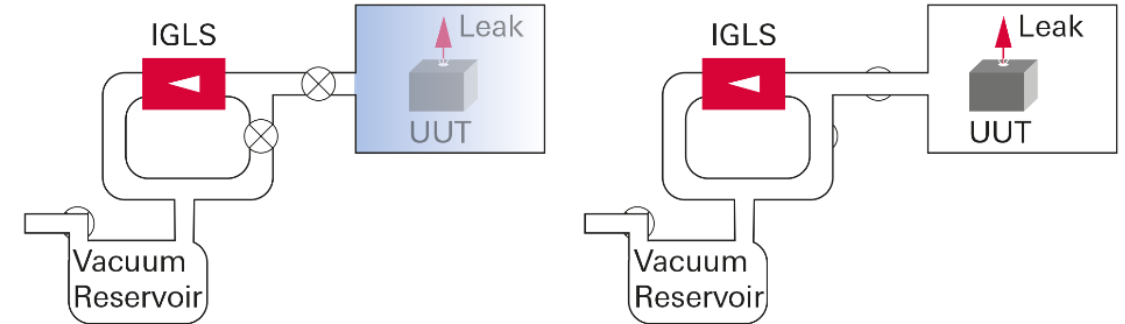

**1 Standby** – Vacuum Reservoir:  $P_0$   
– IGLS: no flow

**2 Fill** – All branches:  $P_0$   
– IGLS: no flow  
– UUT: leaks

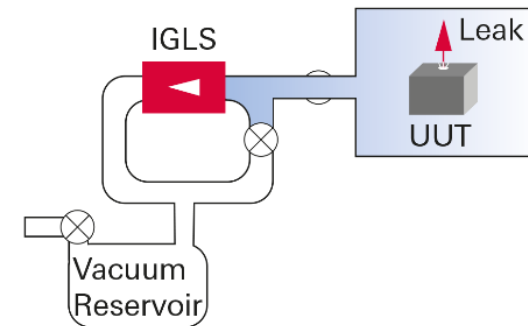

**3 Stabilize** – Leak: increases:  $P_{\text{chamber}}$   
– IGLS: begins flow

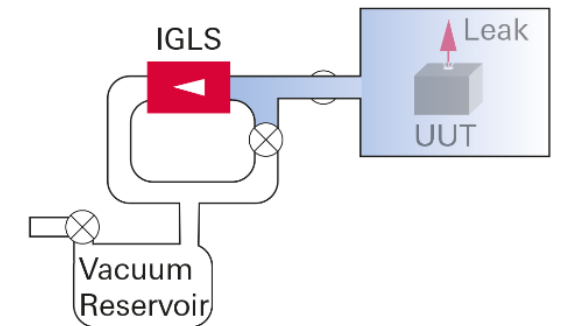

**4 Test** – Steady flow thru leak  
– IGLS: measure flow thru leak

## How it works

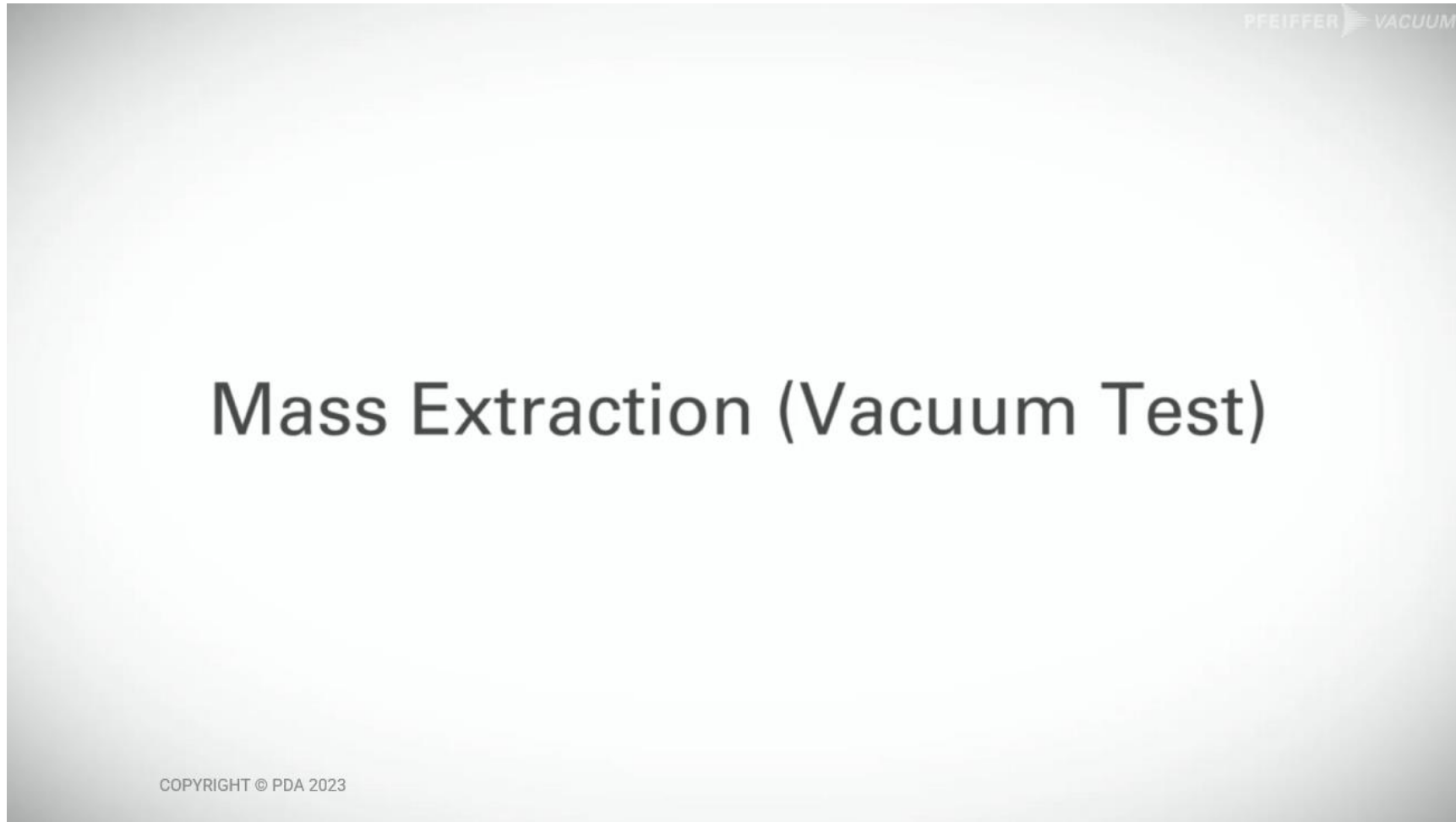





# Patented Sensor Design

Measurement performed: Flow, Pressure Temperature in one sensor.

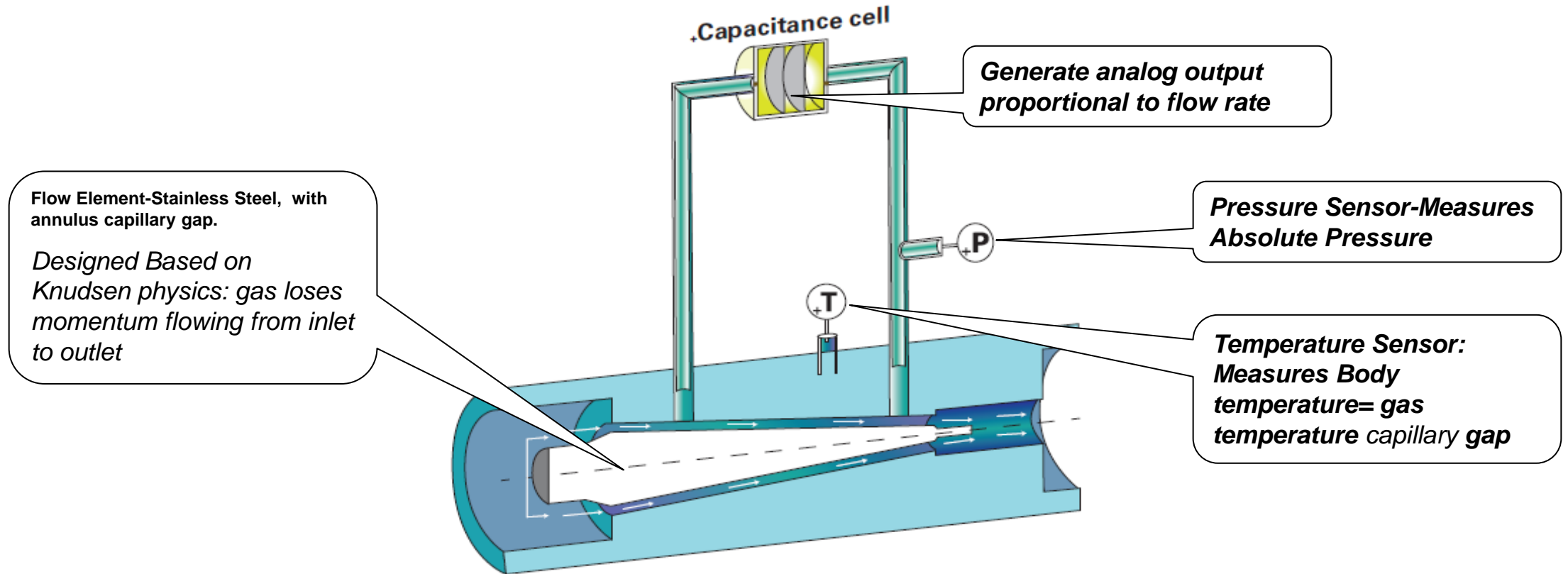

# Test Signature (Glass Vial Test)

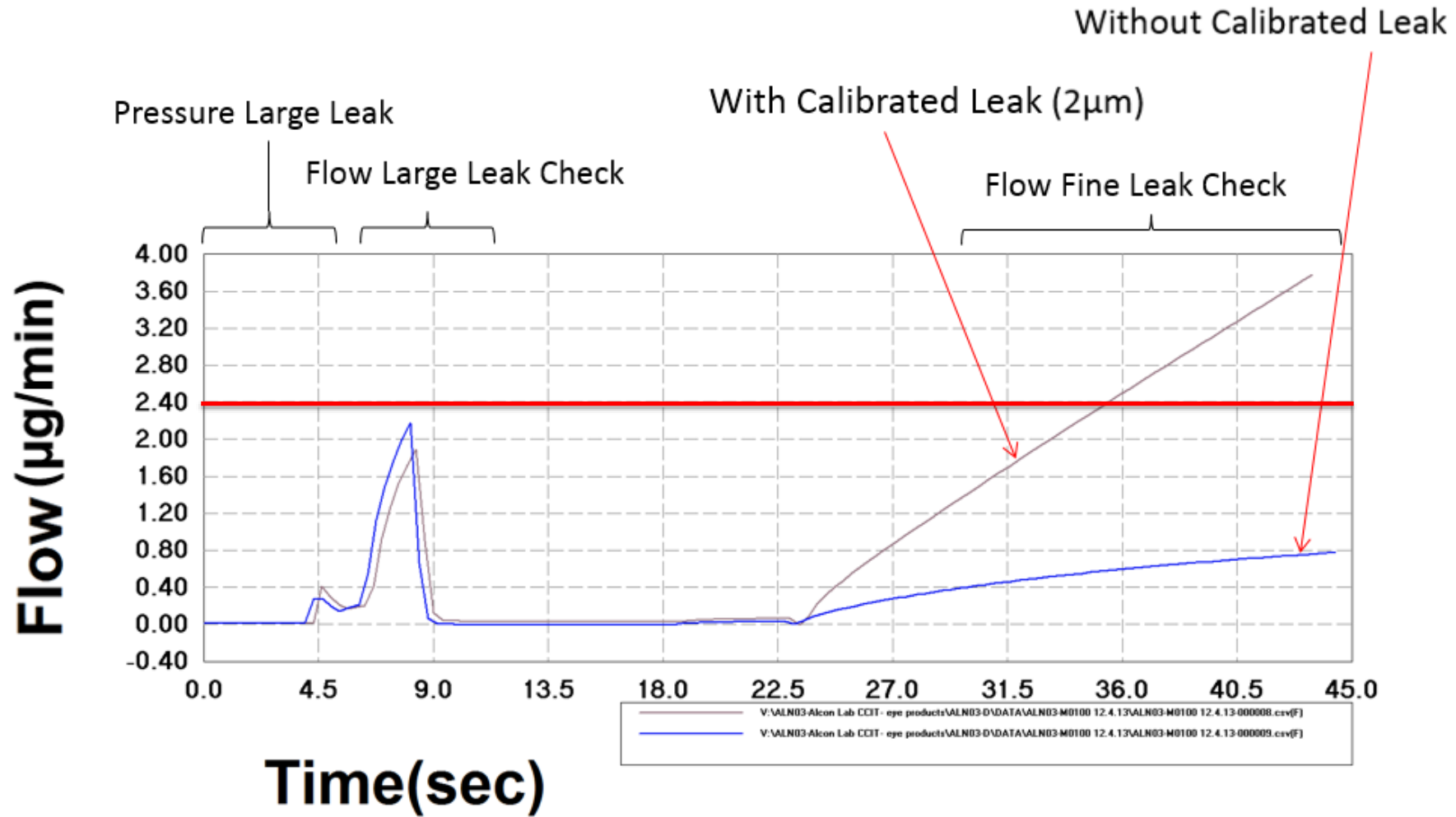

# How it looks (ME2 Cart)



Calibrated leak (inside)

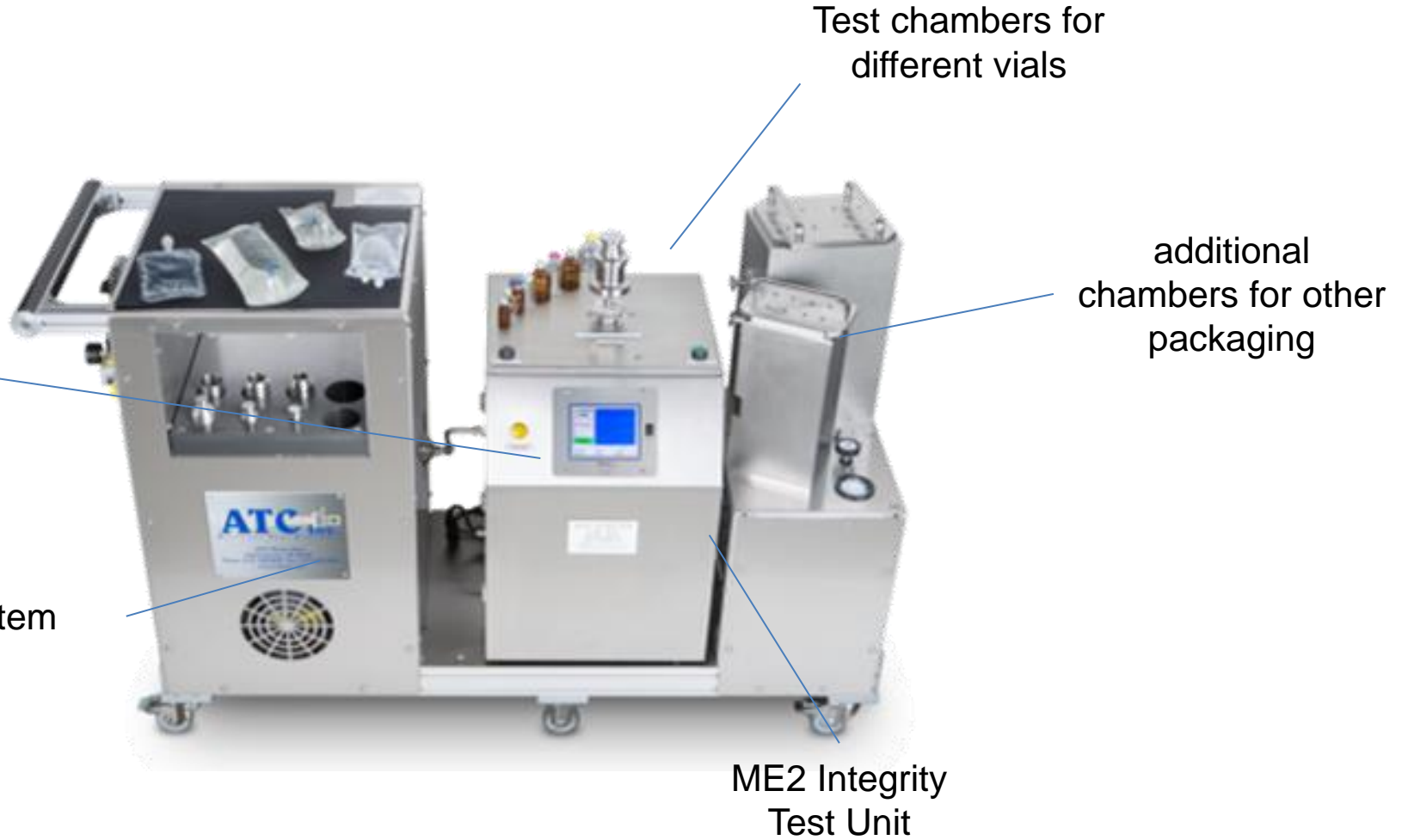

Vacuum System

ME2 Integrity Test Unit

# How it will look: Speedair 3050



Calibrated leak (inside)

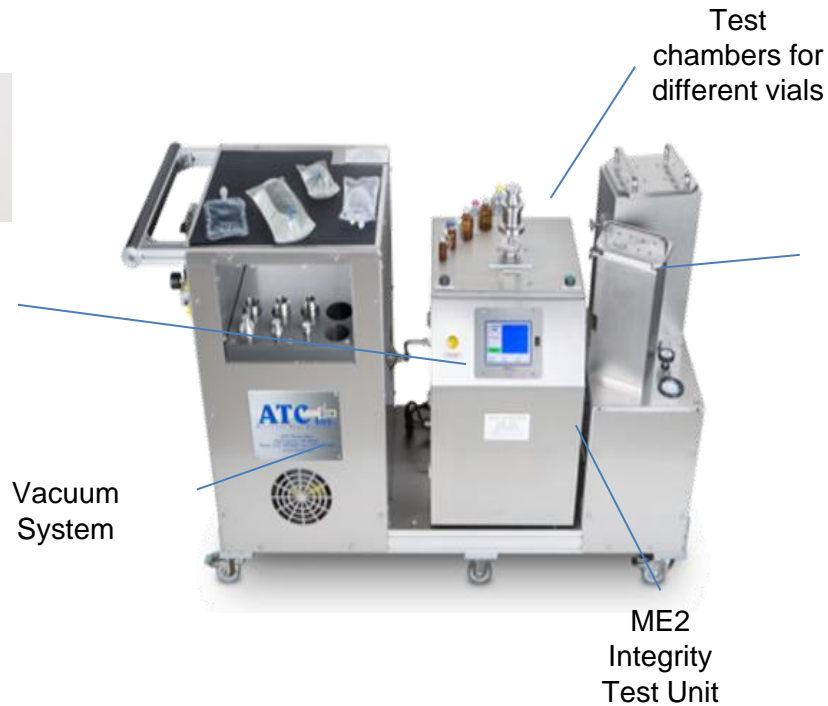

additional chambers for other packaging



## Design Consideration and Test Setup

- Chamber design for consistency and repeatable results
- Built in verification tools are important to identify reject vs. system issues (false reject):
  - Blanks
  - Built in calibration leaks
- One Setup can work for multiple products:
  - Capable Large Leak Check is important for products with very small headspace
  - Finding fine leaks is quite straight forward





# Tooling examples

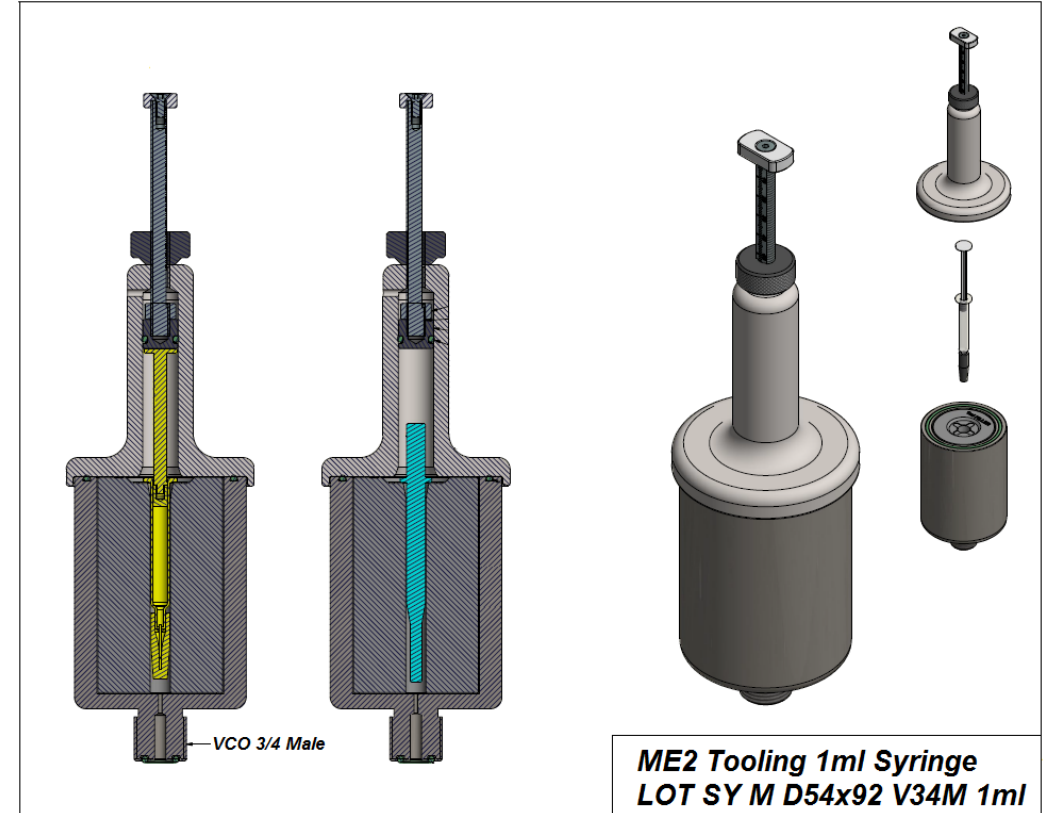
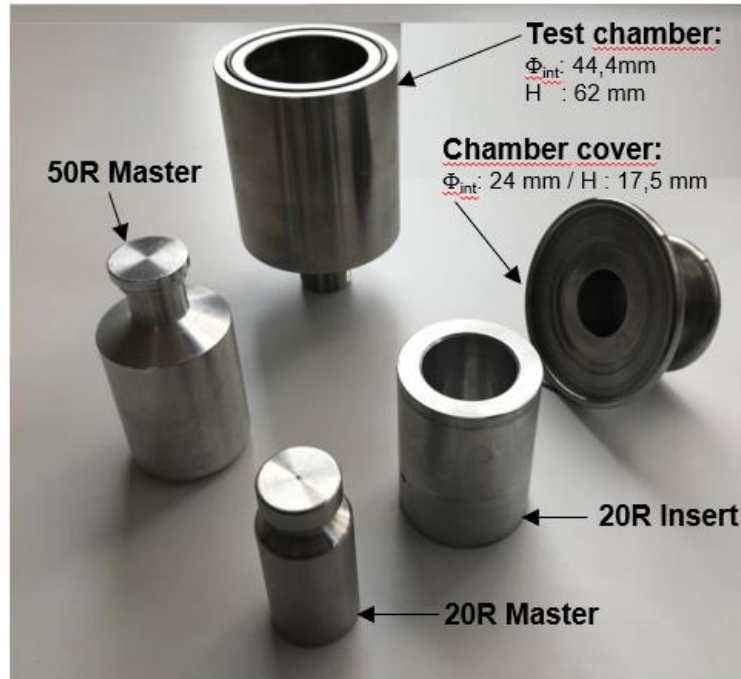
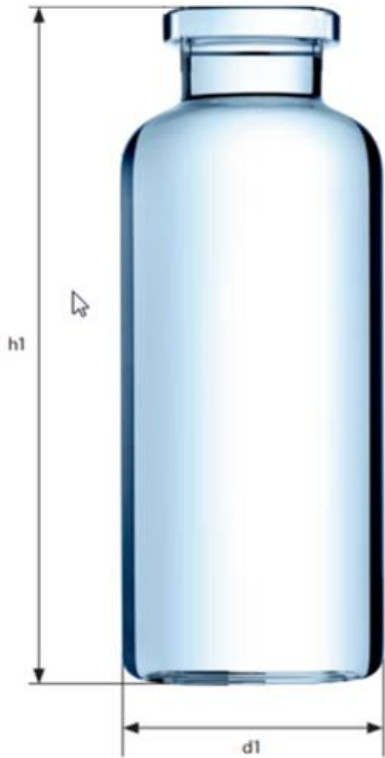



# Case #1: ASTM F3287 Standard



# Instrumentation

- All data collected for this study was generated using an ME2 Mass Extraction flow measurement instrument.
- Each of the 4 laboratories used a different test instrument that was owned and operated by the respective laboratory.
  - No special instrumentation was supplied for the study.
  - Instruments used for completion of this study were used from 2 to 6 years in each of the laboratories.
- Each instrument was the same part number and same measurement range.
- All instruments used the same set-up parameters developed for each container type.
  - No special onsite set-up or parameter adjustment.



Picture shows similar test set up

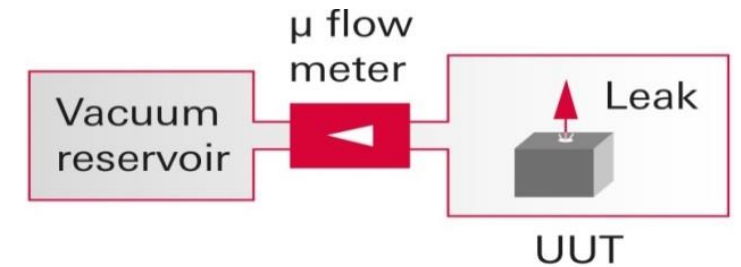

**Measure with Micro-Flow sensor:**  
Gas (Mass) extracted

# Container Types / Samples

A sample set including 123 samples was prepared for the study including 6 container variations as shown below:

- **Glass Vial, Air Filled:** 2mL glass vial with stopper and crimped cap
- **Glass Vial, Liquid Filled:** 2mL glass vial with stopper and crimped cap
- **LDPE Bottle, Air Filled:** 4mL LDPE bottle with a screw cap
- **LDPE Bottle, Liquid Filled:** 4mL LDPE bottle with a screw cap
- **Glass Syringe, Air Filled:** 1mL glass syringe
- **Glass Syringe, Liquid Filled:** 1mL glass syringe

The sample set included both negative and positive control samples. For each container type, a sample set was prepared with WFI (water for injection) inside or air only inside. Three positive controls of each diameter (1µm, 2µm, 5µm, and 10µm) were created for each container variation. Total sample set is shown in Table 1 below:

Empty Container – Sample Set					
Sample Type	Manufactured Defect Sizes (micropipette)				Negative Control
	1 µ nominal	2 µ nominal	5 µ nominal	10 µ nominal	
Glass Vial 2 ml	3	3	3	3	10
Syringe 1 ml	3	3	3	3	10
LDPE Bottle 4 ml	3	3	3	3	10

Liquid Filled Container – Sample Set					
Sample Type	Manufactured Defect Sizes (micropipette)				Negative Control
	1 µ nominal	2 µ nominal	5 µ nominal	10 µ nominal	
Glass Vial 2 ml	3	3	3	Eliminated**	10
Syringe 1 ml	3	3	3	Eliminated**	10
LDPE Bottle 4 ml	3	3	3	Eliminated**	10

\*\*10 µm liquid filled samples were eliminated from the study due to liquid leakage into the test chamber failing gross leak check beginning of test

# Positive Control generation & verification

- Micropipettes were inserted into 18 gauge needles to protect the pipette from damage as they were inserted into containers. Each pipette was bonded inside the needle housing using epoxy.  
 (all artifacts/positives were micro-pipette type, same as used at earlier microbiological ingress studies by Lee Kirsch et al)

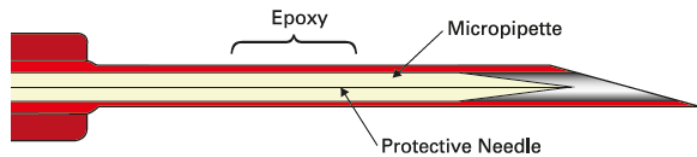

- Air flow rate of each micropipette assembly was measured to ensure that the pipette was not plugged or damaged during assembly (Micropipettes are certified by the manufacturer to be within  $\pm 20\%$  of nominal diameter. This manufacturer's tolerance band results in the flow rate variation measured)

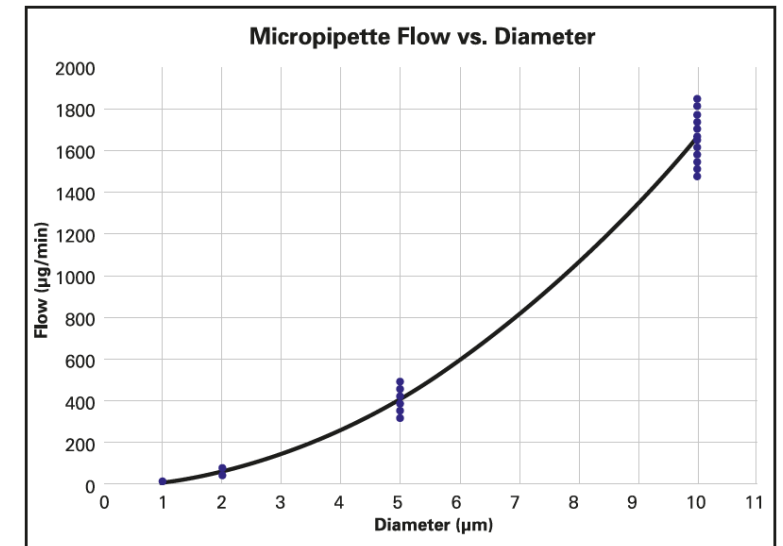

# ASTM F3287 – 17 (Mass Extraction): Result Extract



**TABLE 2 Gas Leak Detection Results—LDPE Bottle 4mL**

NOTE 1—Liquid filled LDPE that included a 10µm micropipette were removed from the sample population due to liquid leakage into vacuum test chamber during CCIT.

Package Description	Number of Samples	Number of Replicate Tests	Number of Failed Tests (Defects Detected)	Number of Passed Tests (No Defects Detected)	Success Rate (% Accurate)
No Defect – Liquid Filled – Negative Control	10	120	0	120	100%
No Defect – Air Filled – Negative Control	10	120	0	120	100%
1 µm micropipette – Liquid Filled	3	36	36	0	100%
1 µm micropipette – Air Filled	3	36	36	0	100%
2 µm micropipette – Liquid Filled	3	36	36	0	100%
2 µm micropipette – Air Filled	3	36	36	0	100%
5 µm micropipette – Liquid Filled	3	36	36	0	100%
5 µm micropipette – Air Filled	3	36	36	0	100%
10 µm micropipette – Air Filled	3	36	36	0	100%

**TABLE 6 Gas Flow Results (µg/min)—LDPE Bottle 4mL**

Package Description	Number of Samples	Average <sup>A</sup>	Repeatability	Reproducibility	Repeatability Limit	Reproducibility Limit
			Standard Deviation	Standard Deviation		
		$\bar{x}$	$s_r$	$s_R$	$r$	$R$
No Defect – Air Filled – Negative Control	10	1.138	0.122	0.137	0.342	0.385
No Defect – Liquid Filled – Negative Control	10	1.132	0.113	0.123	0.318	0.345
1 µm micropipette – Air Filled	3	2.539	0.168	0.195	0.471	0.546
1 µm micropipette – Liquid Filled	2	2.184	0.141	0.174	0.394	0.488
2 µm micropipette – Air Filled	3	7.520	0.135	0.209	0.377	0.585
2 µm micropipette – Liquid Filled	3	6.548	0.127	0.249	0.356	0.696

# Conclusion

- **Glass vials and LDPE Bottles** Mass Extraction tests detected 1µm and 2µm defects at all labs and samples at over 95% confidence level
  - Meets the requirements of USP 1207.1 Table Class (Row) 2 and 3
  
- **Glass syringes** Mass Extraction tests detected 1µm air filled syringes and 2µm air and water filled syringes at all labs and samples. 2µm were detected at a confidence level equal or greater that 95%
  - 1µm liquid filled syringe plugged – suspected by silicon lubricant
  - Samples with 1µm with air under defect can be detected at 95% confidence level
  - Meets the requirements of USP 1207.1 Table 1 Class (Row) 3

	Package Description	Sample Qty.	Qty. of Tests	Qty. of Failed Tests	Qty. of Passed Tests	Success %
Glass Vial 2 ml	Liquid Filled – Negative Control	10	120	0	120	100 %
	Air Filled – Negative Control	10	120	0	120	100 %
	1 µm micropipette – Liquid Filled	3	36	36	0	100 %
	1 µm micropipette – Air Filled	3	36	36	0	100 %
	2 µm micropipette – Liquid Filled	3	36	36	0	100 %
	2 µm micropipette – Air Filled	3	36	36	0	100 %
	5 µm micropipette – Liquid Filled	3	36	36	0	100 %
	5 µm micropipette – Air Filled	3	36	36	0	100 %
	10 µm micropipette – Air Filled	3	36	36	0	100 %
	LDPE Bottle 4 ml	Liquid Filled – Negative Control	10	120	0	120
Air Filled – Negative Control		10	120	0	120	100 %
1 µm micropipette – Liquid Filled		3	36	36	0	100 %
1 µm micropipette – Air Filled		3	36	36	0	100 %
2 µm micropipette – Liquid Filled		3	36	36	0	100 %
2 µm micropipette – Air Filled		3	36	36	0	100 %
5 µm micropipette – Liquid Filled		3	36	36	0	100 %
5 µm micropipette – Air Filled		3	36	36	0	100 %
10 µm micropipette – Air Filled		3	36	36	0	100 %
Glass Syringe 1 ml		Air Filled – Negative Control	10	120	0	120
	1 µm micropipette – Air Filled	3	36	36	0	100 %
	2 µm micropipette – Air Filled	3	36	36	0	100 %
	5 µm micropipette – Air Filled	3	36	36	0	100 %
	10 µm micropipette – Air Filled	3	36	36	0	100 %
	Liquid Filled – Negative Control	10	120	0	120	100 %
	1 µm micropipette – Liquid Filled	3	36	0	36	0 %
2 µm micropipette – Liquid Filled	3	36	36	0	100 %	
5 µm micropipette – Liquid Filled	3	36	36	0	100 %	

# Case #2: Auto Injector



# Container Types / Samples

Fully assembled Autoinjector

- 1 ml long pre-filled glass syringe
- 2.25 ml long pre-filled glass syringe

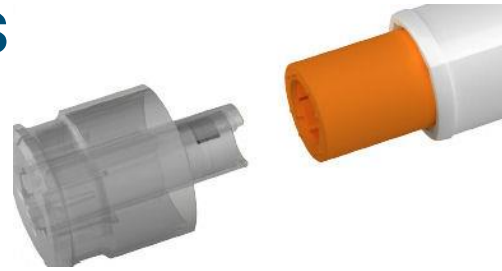

Autoinjector mechanism:

- Wraps syringe
- Includes virtual leaks (trapped air)

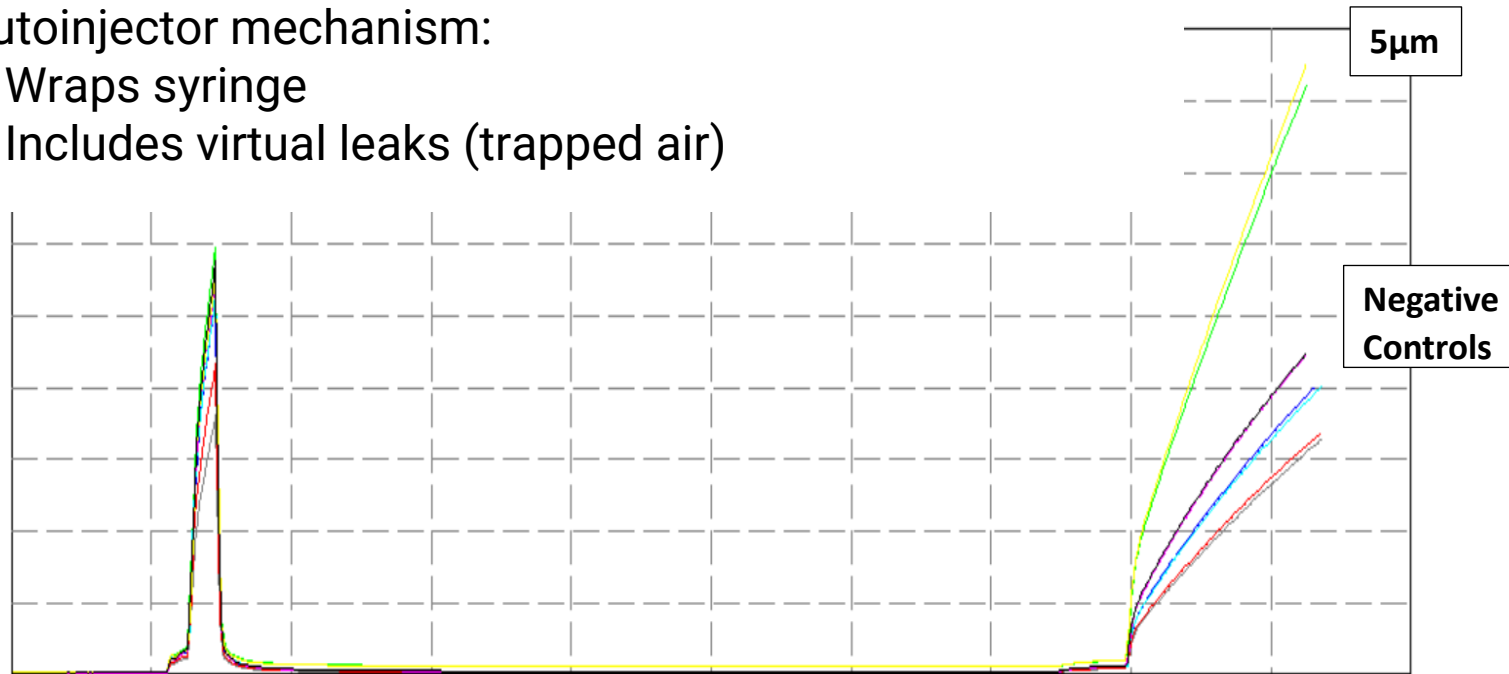



# Case #3: Flexible Bags



## 5L Dual Chamber Dialysate Bags

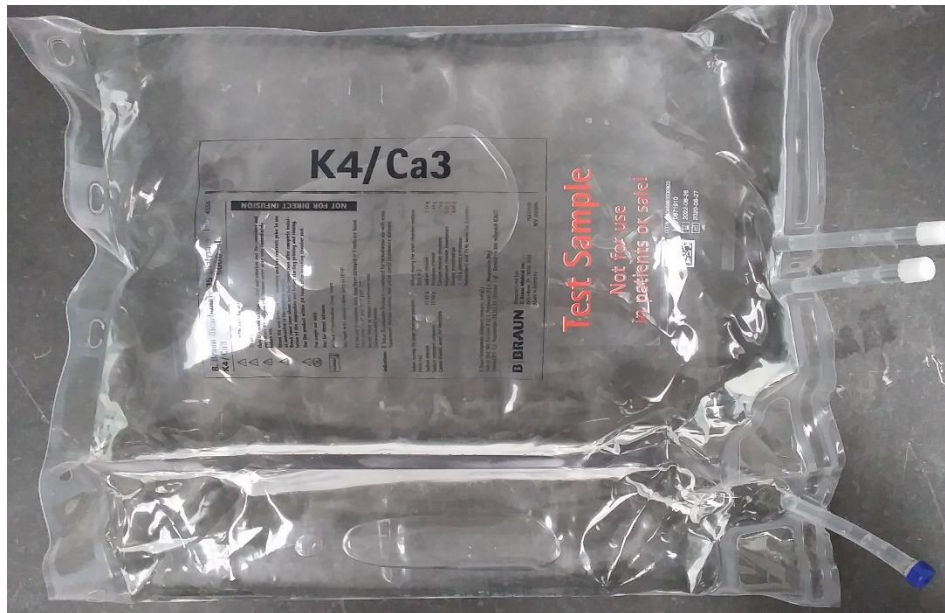

Support of internal bag peel seal

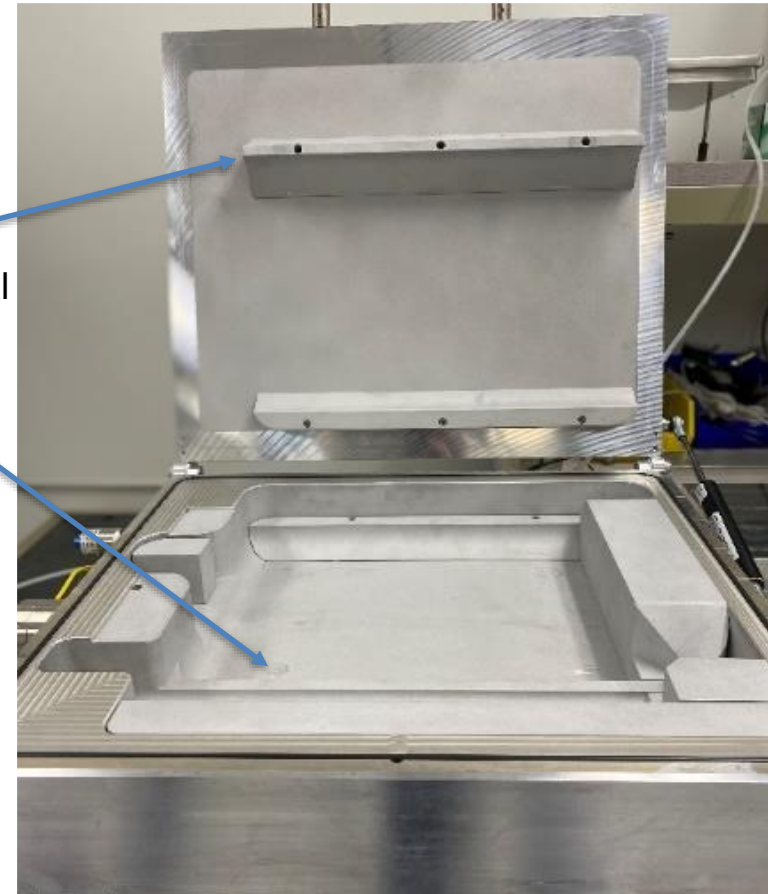

- 50 samples were included in the test
  - 4 for each defect size (2, 5, 10, 20  $\mu\text{m}$ )
  - Simulating liquid & air leak

# 5L Dual Chamber Dialysate Bags

- For air-backed and liquid-backed defects, test time (67 s), detection limit 10µm
- Further trials showed:
  - 5µm defect reliably detected at 135 s
  - 20µm defect reliably detected at 35 s

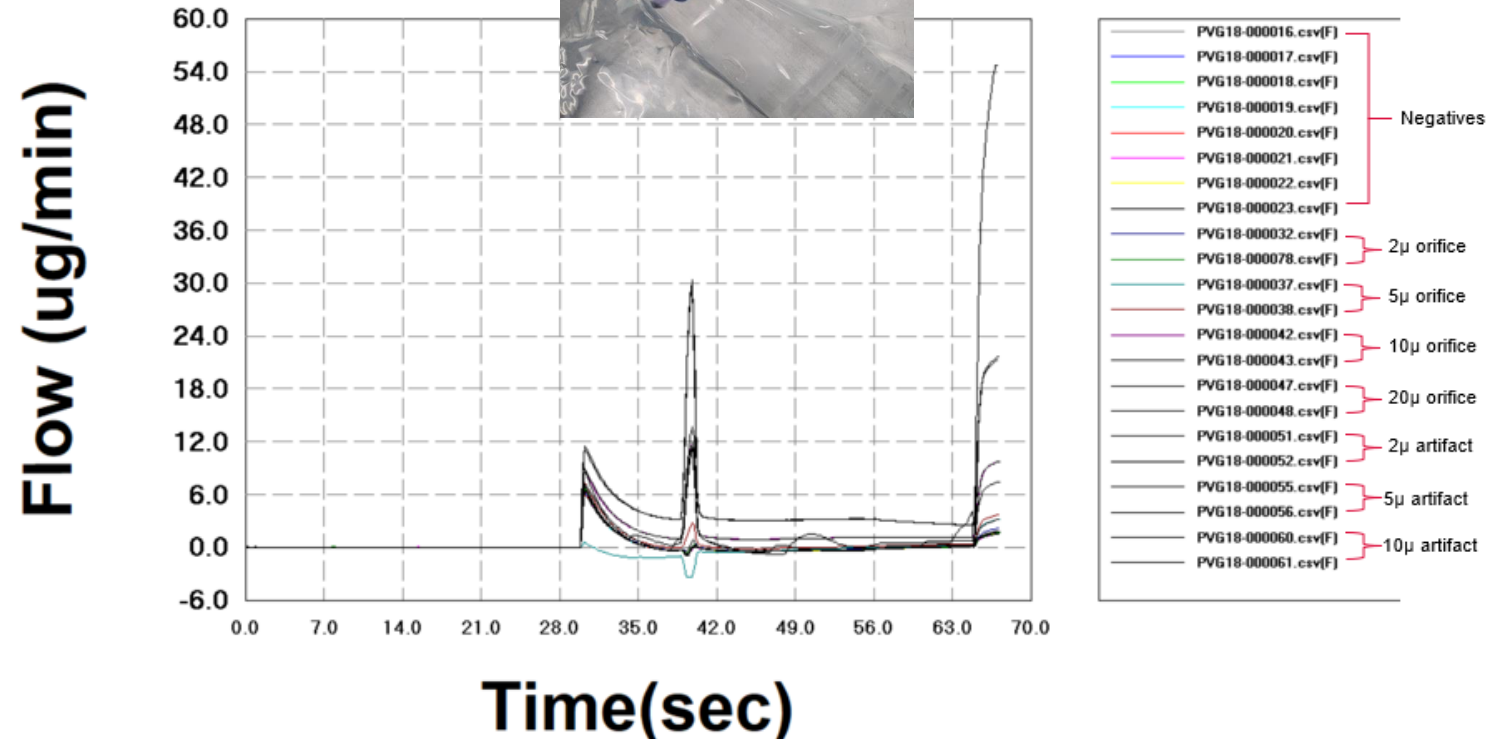
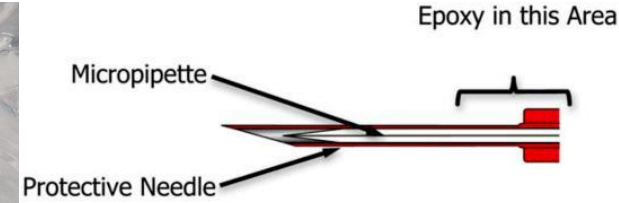
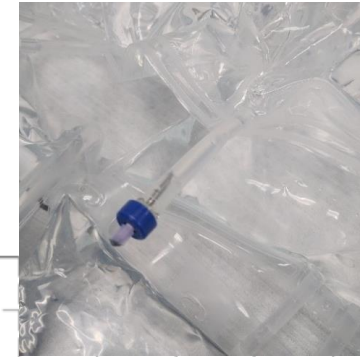

Time = 7.198      Flow = -4.274

# Case #4: Comparative Study Glass Vials

# Case #4: Pfeiffer Vacuum Comparative Study

**Webinar**  
Why and how to replace  
Dye Ingress Test by  
deterministic CCIT  
methods?



STATE  
OF THE  
ART





# CCIT Comparative Study – Sample Preparation

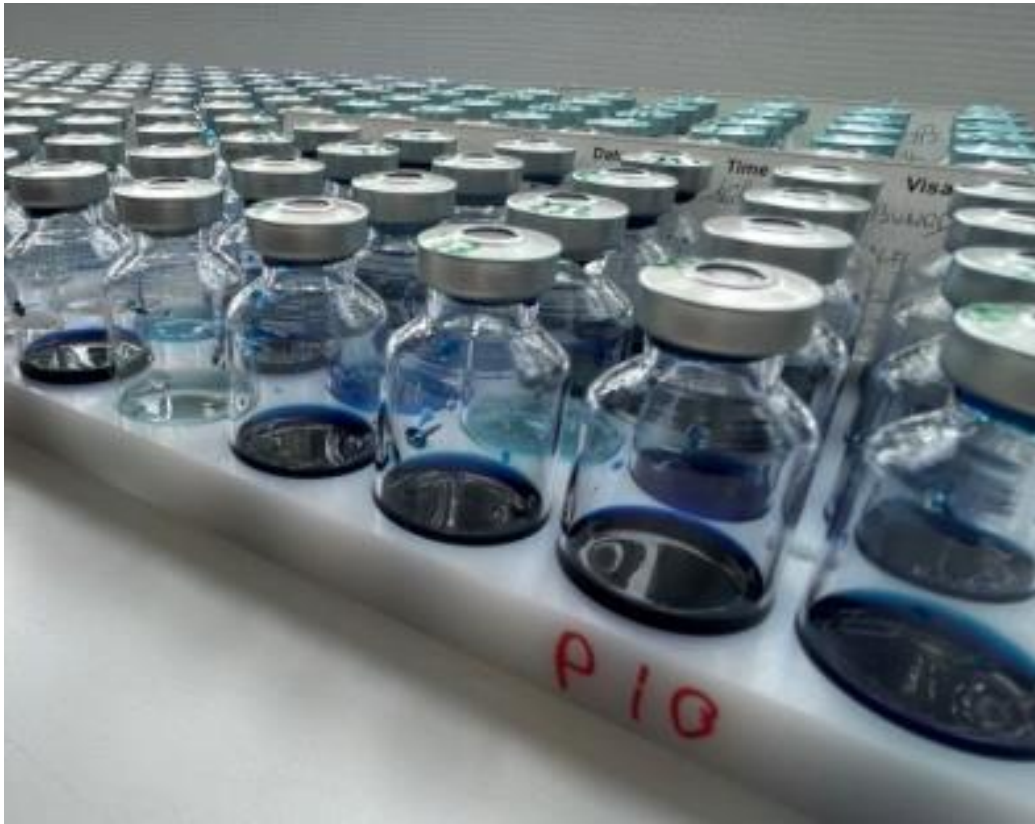

## Microbial Ingress Test, Correlation to Helium Leakage



Kirsch & All, PDA journal, Vol 51, 5, September-October 1997

## Dye Ingress Test, Correlation to Microbial Ingress



Burrell & All – PDA journal, Vol 54, 6, November/December 2000

# CCIT Comparative Study – Sample Preparation

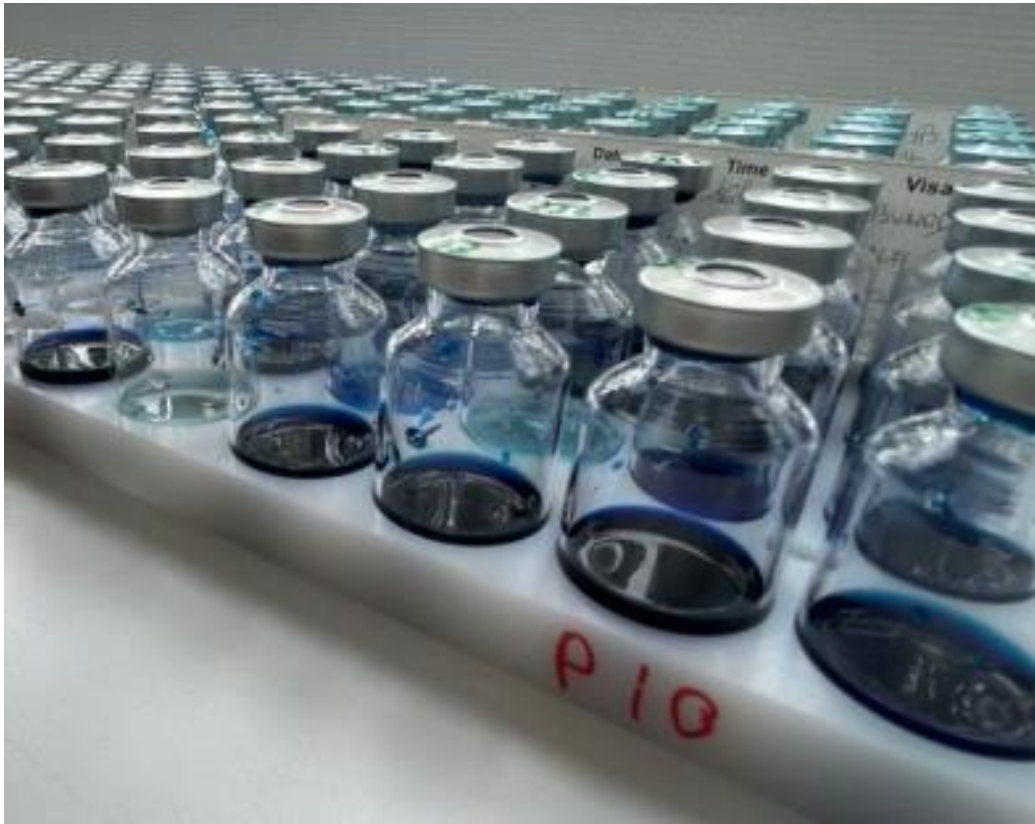

## **Glass $\mu$ -pipettes**

$\Phi$ : 0.1 / 0.2 / 0.4 / 1 / 2 / 5 / 10  $\mu\text{m}$

30 for each diameter

30 Negative controls (glue on the hole)



## **Capillaries (3 cm long)**

$\Phi$ : 2 / 5 / 10 / 15 / 18 / 30 / 40  $\mu\text{m}$

30 for each diameter

30 Negative controls (glue on the hole)

# Summary

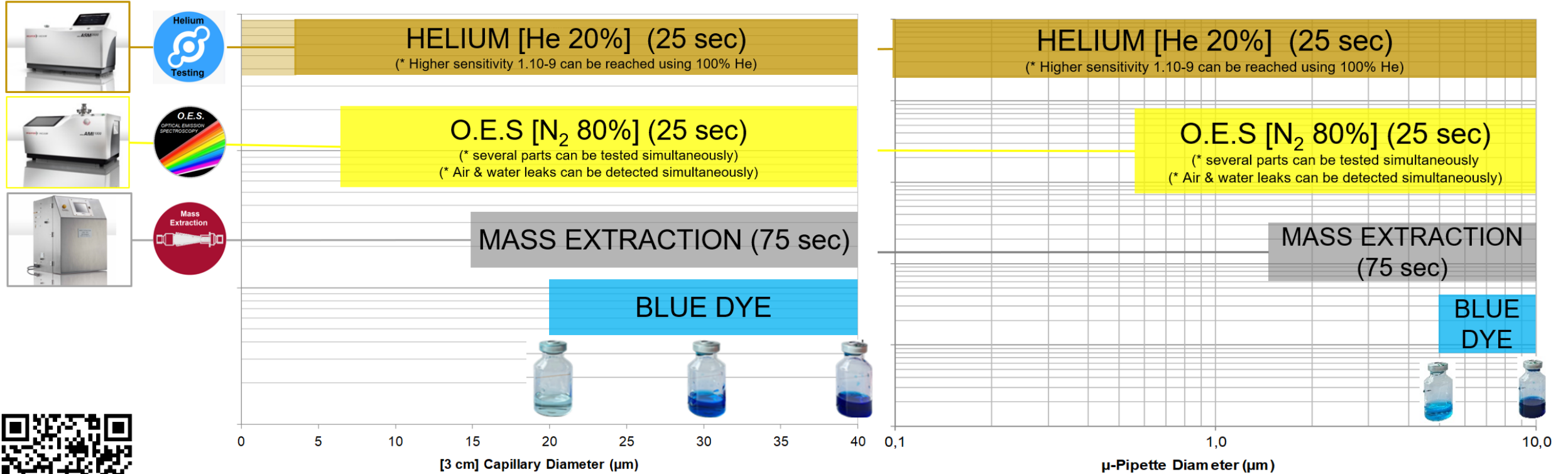



# Summary



## Summary

- Mass Extraction is a USP 1207 recognized deterministic test method for different kinds of pharmaceutical packages and drug types (liquid or solid) – applicable for...



- Equipment can be used for multiple sizes of containers
- Traceable calibration in ISO17025 accredited Laboratory
- 21 CFR part 11 compliant software

# Thank you for your attention !



## Special Thanks to:

- Our pharmaceutical customers
  - collaborating on multiple lab. correlation study
  - use of project tooling and positive/negative control samples
- ASTM for the approval to use data out of official standard