

# Routinely and Operational tests

*A. Kerr, Technical Support Manager, SteriTech Ltd*

# Reference Documents

- **EN285** - European Standard for Large Steam Sterilizers
- **HTM 01-01 (ex CFPP 01-01)** – Management and decontamination of surgical instruments (Medical devices) used in acute care: Part C – Steam Sterilization
- **UNI EN ISO 17665 (Replaces UNI EN 554)** – Sterilization of health care products/Moist heat
- **EN ISO 1140-3 (Replaces EN 867-3)** – Sterilization of health care products. Chemical indicator. Class 2 indicator systems for use in the Bowie and Dick type steam penetration test.

# Air leakage test: Chamber Vacuum Leak Test VLRT

# Air Leakage Test VLRT:

- The air leakage test is used to demonstrate that the quantity of air leakage into the sterilizer chamber during the periods of vacuum does not exceed a level that will inhibit the penetration of steam into the sterilizer load and will not be a potential cause of re-contamination of the sterilizer load during the final vacuum drying phase.
- To verify this, we have to carry out the chamber vacuum leak rate test.

# Air Leakage Test VLRT:

- “If the sterilization process makes use of a vacuum, an air leakage test shall be carried out at specified intervals.”
- (Ref. EN ISO 17665.1 – clause 12.1.5)
- The air leakage test shall be carried out weekly by a CP (Competent Person).
- (Ref. HTM 01-01 Part C)
- EN285 doesn't state frequency that VLRT should be run.

# Air Leakage Test VLRT:

The test should be performed when the chamber is dry and the temperature is stable

The pressure is recorded at different time and the test is satisfactory if:

$$P2 - P1 \leq 20 \text{ mbar}$$

$$P3 - P2 \leq 13 \text{ mbar}$$

P1= pressure value at the test time (time t1)

P2= pressure value after 5 min (time t2)

P3= pressure value after 10 min more (time t3)

Initial vacuum

The chamber is brought to a vacuum of 70 mbar

The valve between the pump and the chamber is closed, the chamber is isolated and the pressure is recorded over the time (t1, t2, t3)

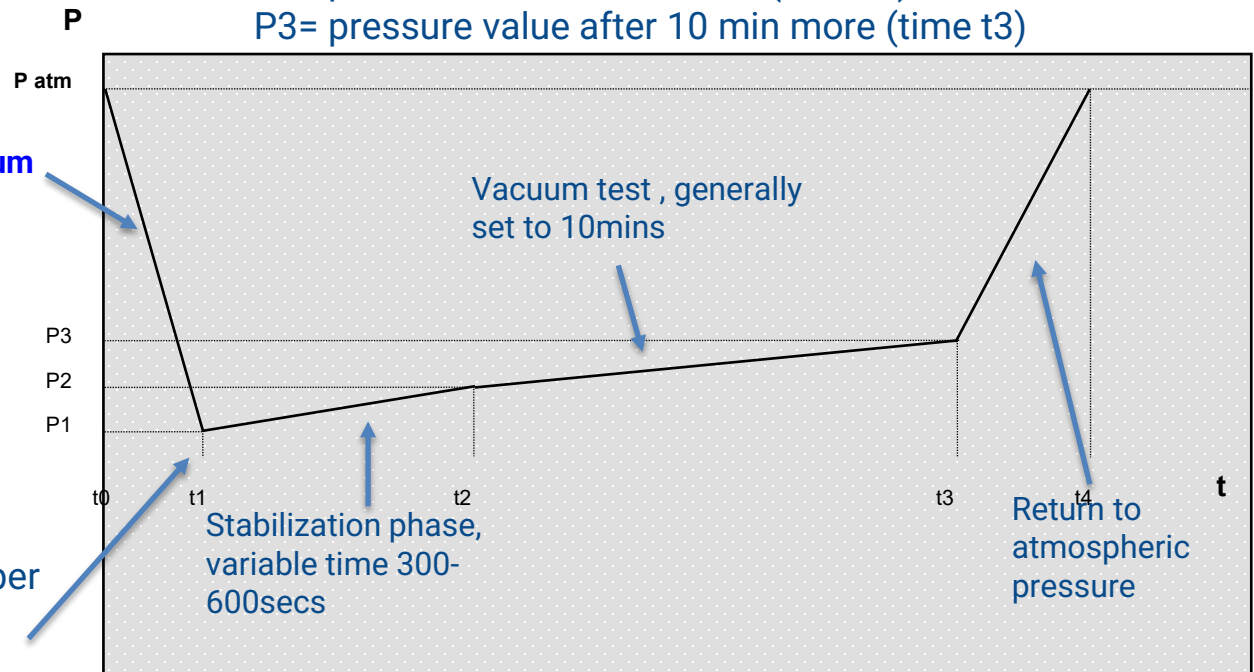

# Air Leakage Test VLRT:

- EN285 limit for VLRT is 1.3mbar per min maximum leakage
- Time for VLRT is not defined in standards, however 10 mins is generally used. Longer VLRT could be used but wont change the result of the test.
- Stabilization phase should be minimum 300secs – 600secs maximum (EN285)
- EN285 Standard does not define how often VLRT should be completed, generally this would be run daily however if it can be demonstrated that the chamber integrity is repeatable then this can be increased.
- What would happen if you run a VLRT monthly and you found at the monthly test you had a big leak ? What would this mean in terms of your product sterility ?

# Air leakage test: Chamber Pressure Leak Test PLRT



# Air Leakage Test PLRT:

- How do we test an autoclave chamber integrity that can only process fluid or sealed containers eg FOA machine ?
- It is not standardized and the definition of rational limits are the responsibility of the autoclave user
- For tightness testing purposes, the chamber is pressurized by compressed air up to 2 to 3 bar abs
- A long stabilization time (up to 30 minutes) is to be foreseen to eliminate the effect of residual pressure loss due to further cooling during the test.
- This test is recommended in the case of contaminant loads
- Leak rate limit to be determined by end user
- Good engineering test to find VLRT leaks.

# Air Leakage Test PLRT:

The test is performed when the chamber is thoroughly dry and at a stabilized temperature

All the valves are closed and the chamber is isolated. The pressure is recorded over the time (t1, t2, t3)

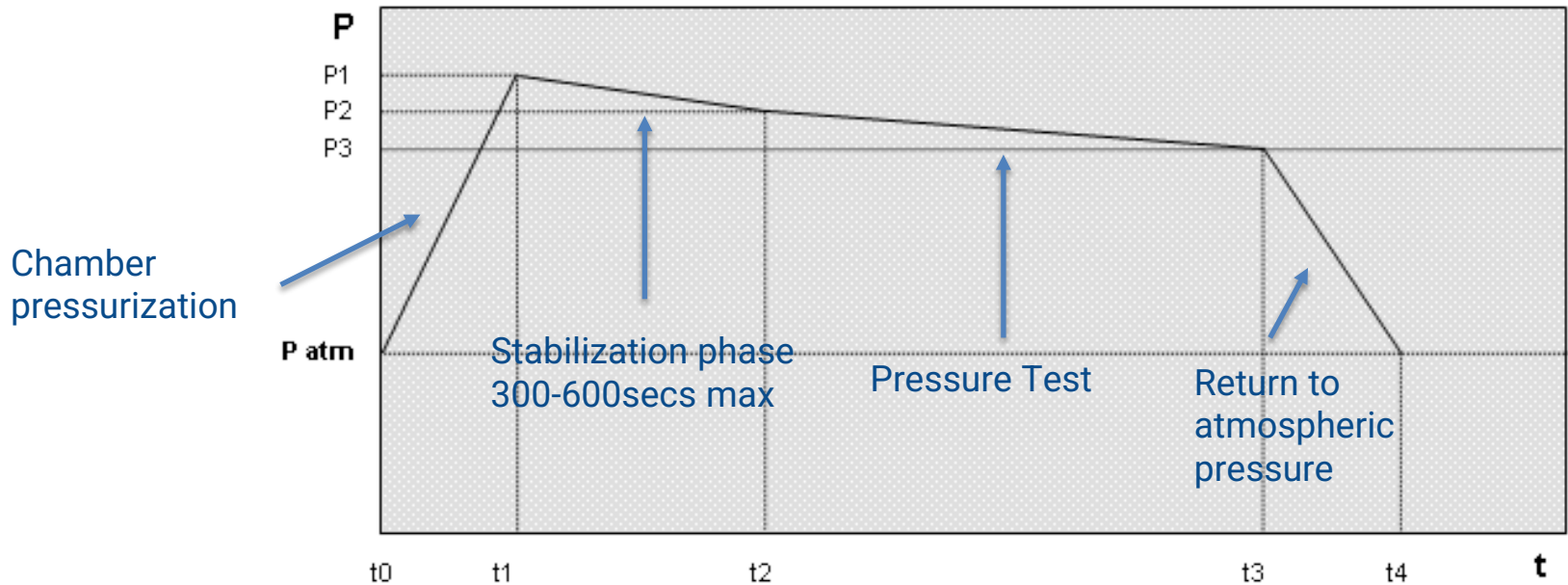

# Bowie & Dick Test

## B&D Test

# Bowie & Dick Test B&D:

- The Bowie and Dick test is used to demonstrate the complete air removal for the rapid penetration of steam in a critical porous load.
- We can use a standard test pack with an indicator sheet compliant with EN ISO 11140-3 in the approximate centre of the pack. Alternatively we can use a “disposable” test pack, single use only.

# Bowie & Dick Test B&D:

- “If the sterilization process relies on the removal of air from the sterilizer chamber in order to achieve rapid and even penetration of steam into the sterilizer load, a steam penetration test shall be carried out each day before the sterilizer is used.”
- (Ref. EN ISO 17665.1 – clause 12.1.6)

# Bowie & Dick Test B&D:



- The test pack is composed by an adequate number of plain cotton sheets, each washed to a good white and having a size of 90 x 120 cm, folded four times and stacked.
- EN285 gives details on washing and folding procedure. Test pack also has to be condition in the correct humidity before use.

# Bowie & Dick Test B&D:

- Halfway along the height of the stack is inserted a sheet of paper measuring 22 x 30 cm. This sheet of paper bears concentric tracks of ink that changes color under humid heat (indicator compliant with EN 11140-3).



# Bowie & Dick Test B&D:

- Its not common that a cotton towel pack is used for the daily B&D test for several reasons. Condition and washing of the towel pack is time consuming, also the folding of the sheets.
- Most commonly used packs are disposable and use a similar type of chemical indicator sheet that changes color if all air has been removed.

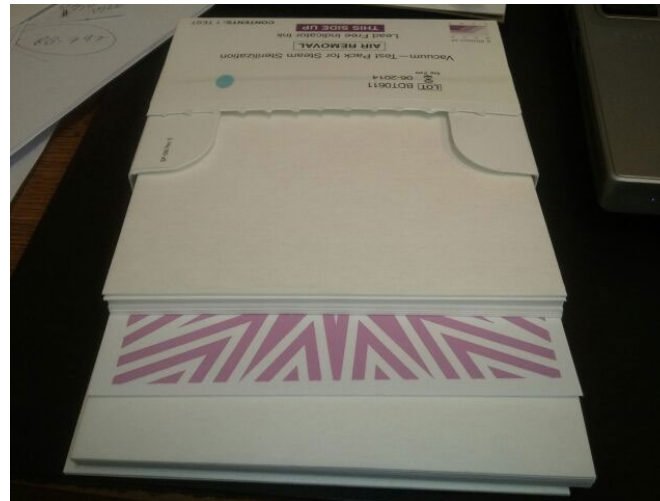



# Bowie & Dick Test B&D:

- Different temperature test packs are available, 121 & 134 deg c
- Test pack defines test time and length , eg 134 deg c for 3.5 mins max
- No extended drying time to be used
- Specific program for Bowie Dick test on machine, however it should represent the production program



# Bowie & Dick Test B&D:

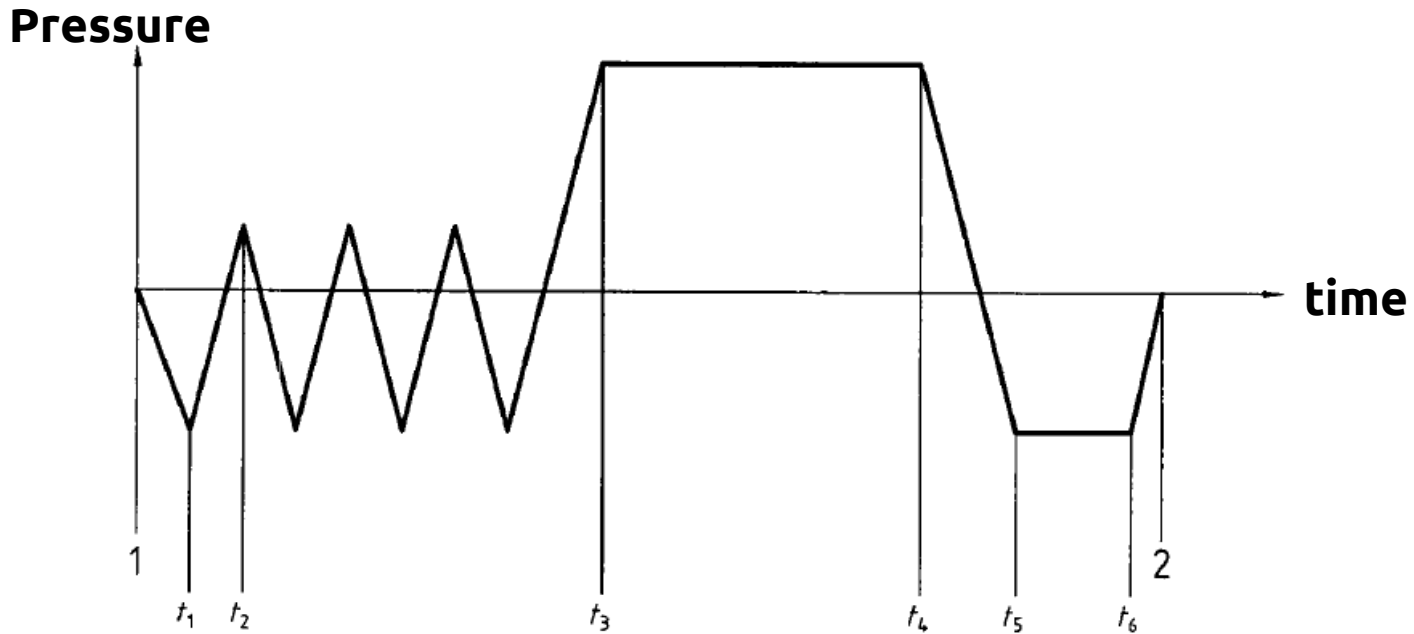

# Bowie & Dick Test B&D:

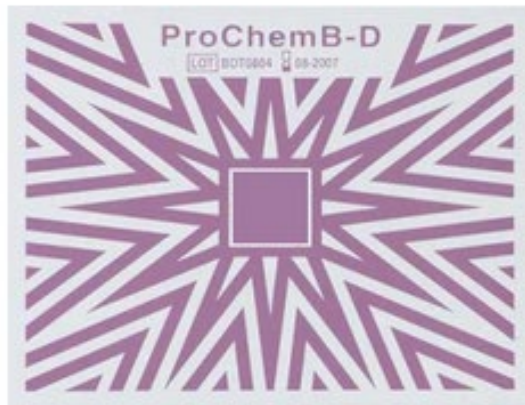

Unexposed

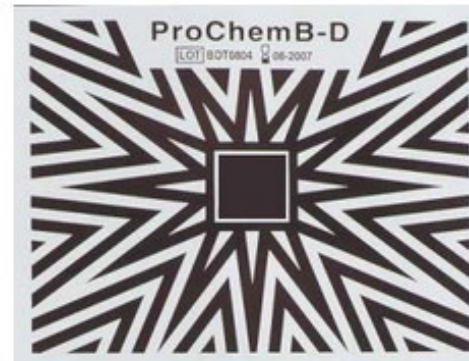

Pass

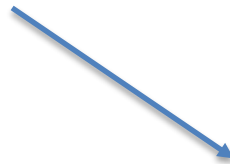

Fail



# Bowie & Dick Test B&D:



## Common reasons of failure

- The air has not been extracted completely from the chamber and therefore from the porous load
- The steam contained unacceptable quantities of non condensable gases (air or CO<sub>2</sub>)
- There is a leak in the chamber

# Bowie & Dick Test B&D:

An unsatisfactory result indicates that the sterilizer should not be used until the fault has been identified and rectified.



- It's common to conduct a series of tests in order to identify the cause of the failed process.
- Verify the efficacy of the air removal phases of the tested cycle
- Conducting an air leak test will identify chamber leaks.
- A steam-quality test for non-condensable gases

# Hollow Load Test

# Helix Test

# Hollow Load Test:

The hollow load test is used to demonstrate that the air has been extracted completely even from critical hollow bodies ( the steam penetrates them adequately)

- Critical Hollow Bodies: reference bodies that are not porous and are structurally provided with recesses that are critical for air elimination and/or steam penetration (ex. pipes that are open at both ends (or at just one end) with a considerable length with respect to the internal opening)

# Hollow Load Test:









- Test device: a tube with a length of 1500 mm, an internal diameter of 2 mm, walls with a thickness of 0.5 mm, connected hermetically to a small cylindrical capsule with an equally hermetic closure; the other end of the tube is open; the material is usually entirely Teflon.
- A strip of paper impregnated with a color changing substance is placed in the capsule.
- All the material for the Helix Test is commercially available.
- The test is passed if the strip of paper changes its color as specified.



# Hollow Load Test:



# Hollow Load Test:

	<p>3.5 min. at 134 °C PCN: PS1410</p> <p>Sterilizing conditions turn indicator from light blue to dark.</p> <p>LOT 121018 STEAM</p>	Unprocessed indicator
	Successfully processed indicator	<div style="border: 2px solid green; padding: 5px; display: inline-block;">PASS</div> 
	Unsuccessfully processed indicator	<div style="border: 2px solid red; padding: 5px; display: inline-block;">FAIL</div> 
	Unsuccessfully processed indicator	<div style="border: 2px solid red; padding: 5px; display: inline-block;">FAIL</div> 
	Unsuccessfully processed indicator	<div style="border: 2px solid red; padding: 5px; display: inline-block;">FAIL</div> 

# Steam Quality Testing

Non-condensable gas test  
Dryness  
Superheat

# Non-condensable Gas Test:

This test is used to demonstrate that the level of non-condensable gases contained in the steam will not prevent the attainment of sterilization conditions in any part of the sterilizer load.

Non-condensable gases are generally air and air is a poor sterilant compared to steam. As an example, a typical dry-heat sterilization exposure phase lasts upwards of two hours at a temperature of at least 160°C/320°F. Steam sterilization typically is done with exposure phases of 15 minutes at 121°C/250°F or 3.5 minutes at 134°C.

# Non-condensable Gas Test:

In short, non-condensable gases decrease sterilization efficacy. The Sterility Assurance Level will be less than expected if non-condensable gas content has increased since product sterility validation.

## ACCEPTANCE CRITERIA

Steam containing up to 3.5ml/ 100ml of condensate

$$C_{NCG} = \frac{V_G}{V_C - V_G} \times 100$$

Description	Test 1	Test 2	Test 3
Volume of water displaced from the burette (V <sub>G</sub> [ml])	3.3	0	0
Volume of water collected in the measuring cylinder (V <sub>C</sub> [ml])	100	0	0
Result (ml NCG/100ml Condensate)	3.412616	#DIV/0!	#DIV/0!

# Non-condensable Gas Test Method :

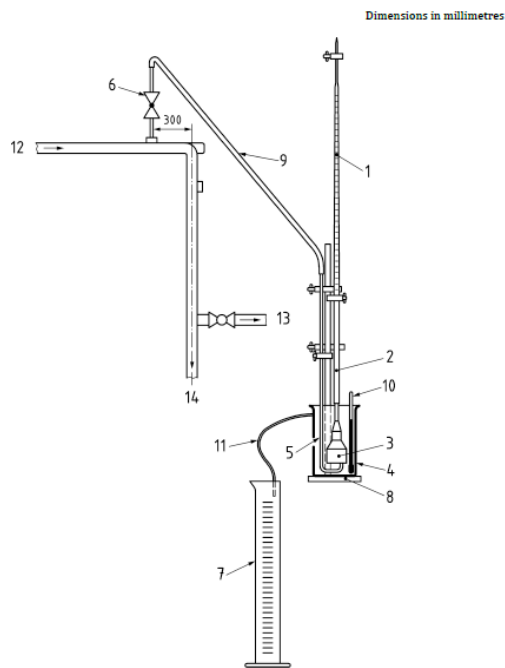

Key					
1	50 ml burette	6	needle valve	12	from steam service
2,9	rubber tubing	7	250 ml measuring cylinder	13	to sterilizer
3	funnel with parallel sides	8	burette stand	14	to trap set
4	2 000 ml container	10	temperature measurement system		
5	steam sampling pipe	11	overflow pipe		

Figure 7 — Diagrammatic representation of the apparatus for the measurement of non-condensable gases

# Non-condensable Gas Test Method :



# Non-condensable Gas Test Method :

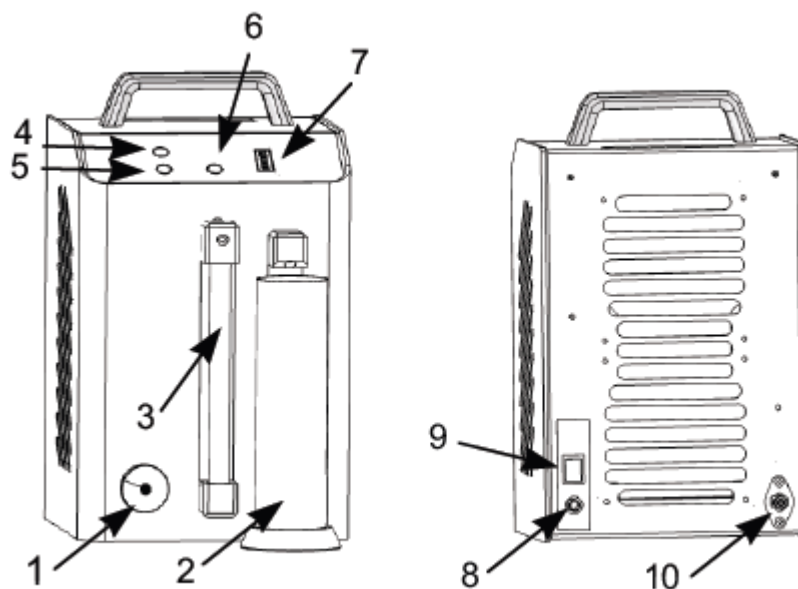



# Non-condensable Gas Test Method :

- Test has to be repeated 3 times
- Use formula to calculate result
- NCG test should always be performed using vertical test point on EN285 SQT test point elbow

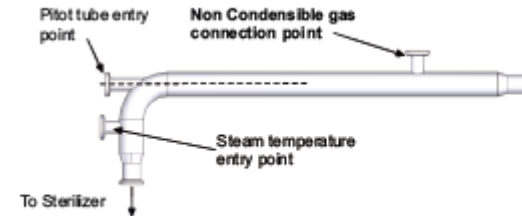

# Non-condensable Gas Test above limit :

What can cause steam to contain NCG above limits ?

- Feed water quality ( Not degassed)
- Steam trap not operating correctly
- Leaks on steam systems, pulling air in etc

[Non-Condensable Gas - Keith Shuttleworth Associates](#)  
[\(ksapharma.com\)](#)

# Dryness Value Test:

## If steam being delivered is too wet

It has a lower enthalpy and delivers a lower amount of heat to the load to be sterilized:  
this results in a longer duration of the process

it wets the products much more than necessary and makes it more difficult or even impossible the  
final drying: the permanence in the time of the sterile condition can become uncertain

Wet steam is the most common reason for wet loads!!!

# Dryness Value Test:

A dryness level down to 90% is considered acceptable for laboratory autoclaves, however, steam below this value is considered to be wet steam.

If the steam is wet the expected Sterility Assurance Level is probably not being achieved.

## ACCEPTANCE CRITERIA

The dryness value of the saturated steam must be equal/higher than 0.95%

# Dryness Value below 95%:

What can cause wet steam ?

- Steam line not properly lagged
- Steam traps not operating correctly
- Pressure drop in steam production
- Test method

# Dryness Value Test Method:

Description	Test 1	Test 2	Test 3
Total weight of flask, pipes etc. ( $m_e$ [kg])	0.663	0.663	0.663
Total weight of flask and 650ml of water ( $m_s$ [kg])	1.313	1.313	1.313
Total weight of flask + condensate ( $m_f$ [kg])	1.391	1.391	1.391
Initial temperature of water ( $T_1$ [°C])	21	21	21
Final temperature of water and condensate ( $T_2$ [°C])	81.4	81.4	81.4
Average temperature of steam delivered to steriliser ( $T_3$ [°C])	143.4	143.4	143.4
Latent heat of average temperature of steam delivered to steriliser ( $L$ [kJ/kg])	2134.34	2134.34	2134.34
<b>Dryness value</b>	<b>0.95</b>	<b>0.95</b>	<b>0.95</b>

$$D = \frac{(T_2 - T_1) [c_{pw} (m_s - m_e) + A]}{L(m_f - m_s)} - \frac{(T_3 - T_2) c_{pw}}{L}$$

where

- $L$  is the latent heat of saturated steam at temperature  $T_3$ , in kilojoules per kilogram;
- $m_e$  is the mass of the Dewar flask and rubber stopper assembly, pipes and tube, in kilograms;
- $m_s$  is the mass of the Dewar flask, water charge rubber stopper assembly pipes and tube, in kilograms;
- $m_f$  is the mass of the flask, water charge, condensate, rubber stopper assembly, pipes and tube, in kilograms;
- $T_1$  is the initial temperature of the water in the Dewar flask, in degrees Celsius;
- $T_2$  is the final temperature of the water, and condensate in the Dewar flask, in degrees Celsius;
- $T_3$  is the temperature of saturated steam delivered to the sterilizer, in degrees Celsius;
- $c_{pw}$  is the specific heat capacity of water (4,18 kJ/kg · K);
- $D$  is the dryness value of the steam;
- $A$  is the effective heat capacity of the apparatus (0,24 kJ/K).

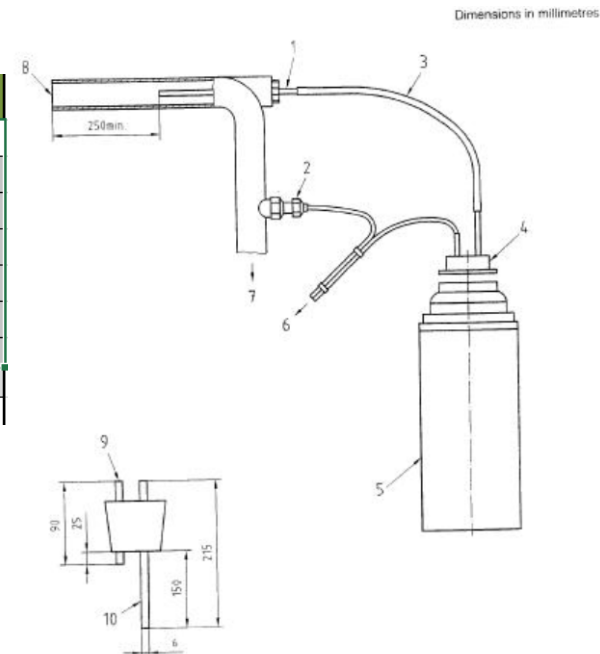

**Key**

- 1 pilot tube
- 2 temperature sensor entry gland
- 3 rubber tubing
- 4 rubber bung assembly
- 5 one-litre Dewar flask
- 6 to temperature measuring instrument
- 7 to sterilizer
- 8 from steam service
- 9 pipe for thermocouple and vent
- 10 sample pipe

[Dryness Value Test - Keith Shuttleworth Associates \(ksapharma.com\)](http://ksapharma.com)



# Super Heat test:

The steam is sampled in free expansion into ambient air. (Pitot tube)

The maximum temperature measured at a precise location in the jet is the temperature upon which the superheat analysis is based.

When the temperature and moisture content do not match up, two things can happen:

1. If the moisture content is higher than saturation for the temperature, wet loads occur; When the moisture content is lower than saturation for the temperature, the condition is called superheat.
2. When the moisture content is lower than saturation for the temperature, the condition is called superheat.

# Super Heat test:

In superheat, the steam is too dry and its energy content is too high, this may damage heat-sensitive products. It makes uncertain the presence of water in its liquid state on the surface of hard / porous loads: this means the risk of not satisfying one of the basic conditions for the sterilization by moist heat.

## ACCEPTANCE CRITERIA

The amount of superheat present in the steam should be no more than 25 degrees Kelvin (~25 degrees Celsius) above the temperature in free expansion into atmosphere at the current atmospheric pressure.

Test has to be performed once only. Other test 3 repeats are required.

# Super Heat test Method:

Dimensions in millimetres

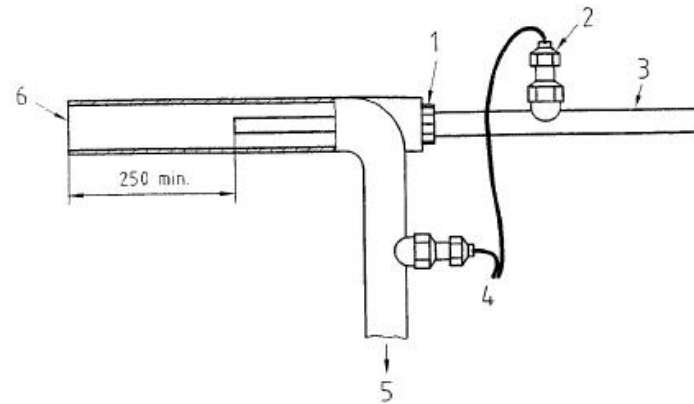

**Key**

- |   |                            |   |                                     |
|---|----------------------------|---|-------------------------------------|
| 1 | pitot tube                 | 4 | to temperature measuring instrument |
| 2 | temperature sensor fitting | 5 | to sterilizer                       |
| 3 | expansion tube             | 6 | from steam service                  |

[Superheat Test - Keith Shuttleworth Associates](#)  
[\(ksapharma.com\)](#)